



Mini-excavator

Engine power
6.8 kW / 9.1 HP @ 2200 rpm

Operating weight
880 - 1080 kg

Bucket capacity
0.016 - 0.025 m³

PC09-1



Engine power

6.8 kW / 9.1 HP @ 2200 rpm

Operating weight

880 - 1080 kg

Bucket capacity

0.016 - 0.025 m³

High versatility, extremely compact and **safe performance in tight spaces**

Outstanding performance

- Agile and precise
- Extremely compact
- Superior hydraulic system
- Excellent efficiency and reliability

Total versatility

- Two travel speeds
- Variable width undercarriage
- Arm with integrated demolition breaker (option)

Extremely robust

- Cast body
- Tubular boom
- Metal bonnet

Safe and environment friendly

- Safety lock lever
- Recycle-oriented design
- Low noise levels

Easy maintenance

- Easy access to all inspection points
- Full opening bonnet
- Long interval greasing



Outstanding performance



Extremely compact

The new PC09-1 micro-excavator has exactly the right power and digging force for operating in tight spaces: ideal inside buildings, for small demolition work, to set plants or install an irrigation system in a garden, and, in general, on any job site where a bigger machine can't work or even be transported to.

Superior hydraulic system

Thanks to its cutting edge hydraulic system, all movements - even when combined - are smooth and shock-free for maximum precision, in any application. The PC09-1 is a perfect mix of the care that a manual worker can bring to a job and of an excavator's high performance. It makes any job much easier and quicker to finish.

Total versatility

Variable width undercarriage

For applications requiring maximum versatility in terms of size and stability, the PC09-1 is equipped with a hydraulic undercarriage extension operated from the driver's seat via a dedicated control. This feature allows the operator to quickly switch from maximum stability for digging, to a reduced width of less than one meter to easily drive through narrow passages or doors.

Arm with integrated demolition breaker (option)

With this option, the PC09-1 can switch from a digging job to a demolition application in just a few seconds: You can use the breaker without removing the bucket, by simply installing the provided point. The PC09-1 then becomes a 2-in-1 machine and you don't need to carry other special tools for top functionality and efficiency.





Built to last

Several technical solutions give the PC09-1 increased sturdiness and operability. The cast body offers extreme rigidity and robustness, and the metal bonnet guarantees a longer life and lower repairing costs in the event of a collision. A special tubular boom with no welding houses all hydraulic hoses and protects them from possible damage while allowing complete visibility of the digging area.



Specifications

Engine

Model	Komatsu 2D68E-3A
Displacement	522 cm ³
Engine power	
at rated engine speed	2200 rpm
ISO 14396	6.8 kW / 9.1 HP
ISO 9249 (net engine power)	6.3 kW / 8.4 HP
Cooling system	Water

Operating weight (appr.)

Operating weight with standard bucket, fully serviced, +75 kg operator (ISO 6016)

Operating weight with rubber shoes	880 kg
Arm with hydraulic breaker	+100 kg (option)
TOPS canopy	+100 kg (option)

Hydraulic system

Main pumps	2 × gear pump
Max. pump flow	11 + 11 l/min
Max. operating pressure	16 MPa (160 bar)
Max. breakout force	1130 daN (1075 kg)

Hydraulic breaker

Impact energy	108 J (11 kgm)
Impact rate	800 bpm

Dimensions

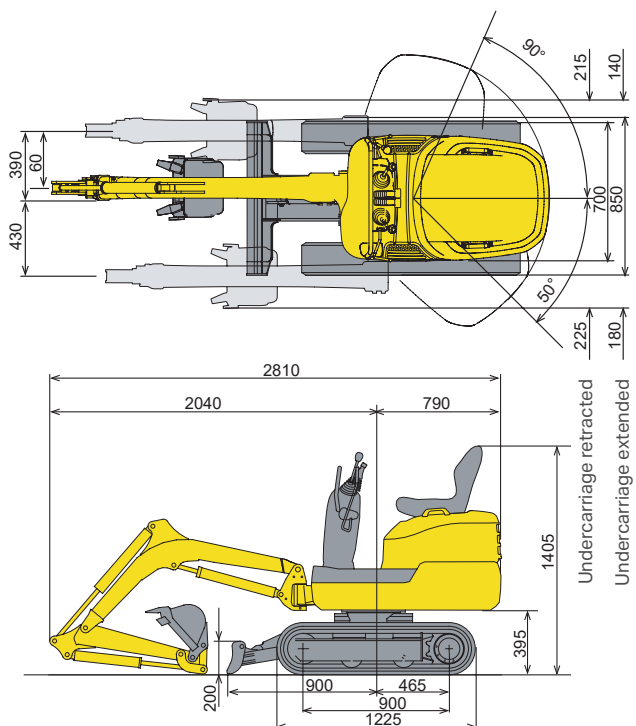

Undercarriage

Blade - Width × height	700 × 200 mm
Shoe width	180 mm
Ground pressure (standard)	0.25 kg/cm ²
Variable undercarriage	

Transmission

Type	Double speed hydrostatic transmission, controlled and steered by means of two levers
Max. drawbar pull	1160 daN (1090 kg)
Travel speed	1.5 - 3.0 km/h

Service refill capacities

Fuel tank	10.8 l
Engine oil	1.9 l
Hydraulic oil tank	16.4 l

Environment

Engine emissions Fully complies with EU Stage V exhaust emission regulations

Noise levels

LwA external	91 dB(A) (2000/14/EC Stage II)
LpA operator ear	74 dB(A) (ISO 6396 dynamic test)

Vibration levels (EN 12096:1997)

Hand/arm	≤ 2.5 m/s ² (uncertainty K = 0.1 m/s ²)
Body	≤ 0.5 m/s ² (uncertainty K = 0.0 m/s ²)

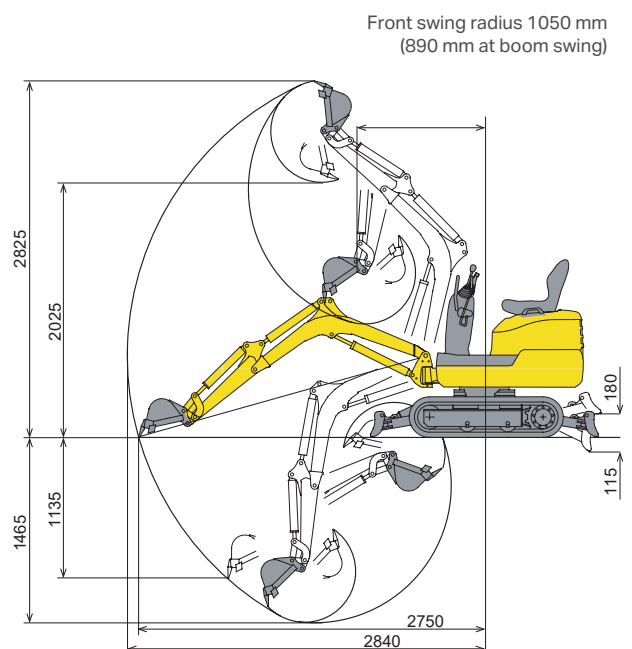

Standard and optional equipment

Standard equipment

Two travel speeds	●
Variable undercarriage	●
Front blade	●
ORFS connections	●
One piece cast iron frame	●
Metal bonnet	●
Safety lock lever	●

Optional equipment

Arm with hydraulic breaker	○
TOPS canopy	○
Komatsu buckets	○

Fuel:
Diesel fuel, conforming to EN590 Class 2/Grade D. Paraffinic fuel capability
(HVO, GTL, BTL), conforming to EN 15940:2016

Your Komatsu partner:

KOMATSU

[komatsu.eu](https://www.komatsu.eu)

