

KOMATSU

D65EX-18 **D65PX-18** **D65WX-18**

EU Stage IV Engine

CRAWLER DOZER

PRELIMINARY



D65

ENGINE POWER

164 kW / 220 HP @ 1.950 rpm

OPERATING WEIGHT

D65EX-18: 20.500 kg
D65PX-18: 22.100 kg
D65WX-18: 21.400 kg

BLADE CAPACITY

3,69 - 5,90 m³

Walk-Around

OUTSTANDING PRODUCTIVITY & FUEL ECONOMY

High productivity & low fuel consumption

- Low consumption EU Stage IV engine
- Unique torque converter with auto lock-up
- Automatic transmission
- Adjustable Eco-gauge and auto idle stop
- Selectable working modes

Optimized work equipment

- Sigmadozer® blade with hydraulic pitch
- INPAT blade
- Multishank parallelogram ripper
- Komatsu-Topcon machine control systems



images may display optional equipment or specifications not available in your area.

D65EX/PX/WX-18

First-Class Operator Comfort

- Quiet and comfortable cab
- Fully adjustable air suspension seat
- Superior visibility on blade and ripper
- Less noise and vibrations
- Integrated rear view camera system

State of the art controls

- Hydrostatic steering system
- Gearshift preset function
- Easy and precise
- Remote safety lock levers
- Large TFT colour multi monitor

Tough and reliable

- Low-drive “PLUS” undercarriage
- Self-adjusting idler support
- Sturdy, rugged design
- Stable in any configuration (EX/WX/PX)

KOMTRAX™

- Komatsu Wireless Monitoring System



New, low consumption Komatsu SAA6D114E-6 engine for greatly increased productivity.



New heavy-duty after treatment system combines the Komatsu Diesel Particulate Filter (KDPF) and Selective Catalytic Reduction (SCR) to fully comply with EU Stage IV emissions.



Fully air suspended operator station ensures maximum operator comfort and an excellent view on the blade.



Eco gauge, eco guidance and fuel consumption gauge help to further reduce consumption.



Complimentary maintenance program for customers

ENGINE

Model Komatsu SAA6D114E-6
 Type Common rail direct injection, water-cooled, emissionised, turbocharged, after-cooled diesel
 Engine power
 at rated engine speed 1.950 rpm
 ISO 14396 164 kW / 220 HP
 ISO 9249 (net engine power) 162 kW / 217 HP
 No. of cylinders 6
 Bore x stroke 114 x 144,5 mm
 Displacement 8,85 ltr
 Engine emissions Fully complies with EU Stage IV exhaust emission regulations

UNDERCARRIAGE

Suspension Oscillating equaliser bar and pivot shaft
 Track roller frame Monocoque, large section, durable construction
 Rollers and idlers Lubricated track rollers
 Tracks PLUS link assembly

TORQFLOW TRANSMISSION

Type Komatsu TORQFLOW
 Torque converter 3-element, 1-stage, 2-phase, water-cooled, with automatic lock-up function
 Transmission Planetary gear, multiple-disc clutch, hydraulically actuated, force-lubricated

DIMENSIONS

	D65EX-18 Sigmadozer®	D65PX-18 Straight Tilt	D65WX-18 Sigmadozer®
A	5.490 mm	5.680 mm	5.500 mm
B	1.880 mm	2.050 mm	2.050 mm
C	3.160 mm	3.160 mm	3.160 mm
D	2.970 mm	2.970 mm	2.970 mm
E	2.970 mm	3.275 mm	2.970 mm
F	610 mm	915 mm	760 mm
G	65 mm	65 mm	65 mm

	D65EX-18 INPAT	D65PX-18 INPAT	D65WX-18 INPAT
A	5.790 mm	5.790 mm	5.790 mm
B	2.050 mm	2.230 mm	2.230 mm
C	3.160 mm	3.160 mm	3.160 mm
D	2.970 mm	2.970 mm	2.970 mm
E	2.970 mm	3.275 mm	2.970 mm
F	560 mm	760 mm	760 mm
G	65 mm	65 mm	65 mm
H	3.545 mm	3.670 mm	3.670 mm

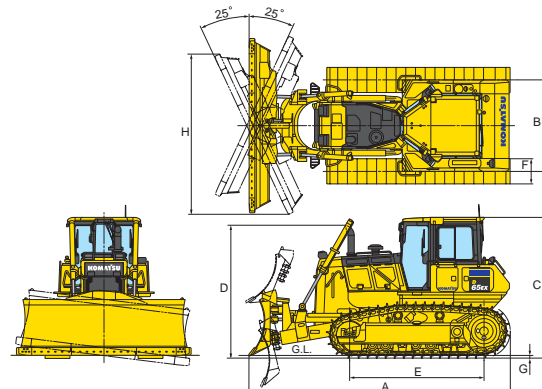
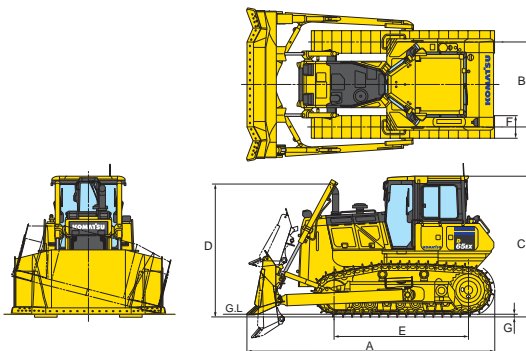

DOZER EQUIPMENT

	Overall length with blade	Blade capacity	Blade width x height	Max. lift above ground	Max. drop below ground	Max. tilt adjustment	Additional weight
D65EX-18 Sigmadozer®	5.490 mm	5,61 m³	3.410 x 1.425 mm	1.135 mm	500 mm	870 mm	2.440 kg
D65EX-18 INPAT	5.790 mm	4,25 m³	3.870 x 1.235 mm	1.170 mm	695 mm	500 mm	2.960 kg
D65WX-18 Sigmadozer®	5.500 mm	5,90 m³	3.580 x 1.425 mm	1.135 mm	500 mm	770 mm	2.550 kg
D65WX-18 INPAT	5.790 mm	4,42 m³	4.010 x 1.235 mm	1.170 mm	695 mm	520 mm	* 2.990 kg
D65PX-18 Straight tilt	5.680 mm	3,69 m³	3.970 x 1.100 mm	1.130 mm	535 mm	890 mm	2.100 kg
D65PX-18 INPAT	5.790 mm	4,42 m³	4.010 x 1.235 mm	1.170 mm	695 mm	520 mm	* 2.990 kg

Blade capacities are based on the SAE recommended practice J1265.

* Foldable INPAT blade (WX/PX): additional weight +330 kg