

KOMATSU



D
37EX/PX

Crawler Dozer

D37EX/PX-23

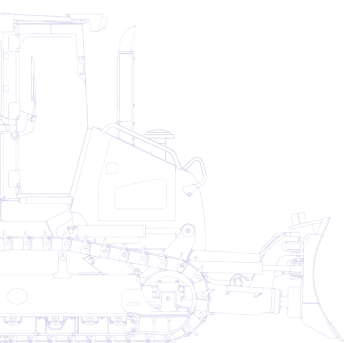

www.marubeni-komatsu.co.uk

ENGINE POWER
67,7 kW / 90,7 HP @ 2.200 rpm

OPERATING WEIGHT
D37EX-23: 8.480 kg
D37PX-23: 8.780 kg

Walk-Around

The Komatsu D37EX/PX-23 dozer offers reliability, versatility - and the best value for your money. Hydraulics, power train and frame, as well as all other major components are directly engineered and manufactured by Komatsu, and they work together perfectly to deliver optimal production levels. A super-slant nose and rear mounted cooler make this dozer unique on the market today. The D37-23 is equipped with a factory-fitted Plug and Play provision kit for easy installation of Topcon 2D and 3D blade control systems, making this Komatsu dozer your perfect partner for automatic applications.

Unmatched visibility and safety

- Unique super-slant nose
- Cab-forward design
- Integrated ROPS/FOPS
- Rear view camera system

High productivity & low fuel consumption

- Low consumption EU Stage IIIB/EPA Tier 4 interim engine
- Highly efficient hydrostatic drive line
- Straight Power Angle Tilt blade with adjustable pitch
- Electronically-controlled, hydraulically-driven fan
- Komatsu-Topcon Plug & Play provisions



ENGINE POWER
67,7 kW / 90,7 HP @ 2.200 rpm

OPERATING WEIGHT
D37EX-23: 8.480 kg
D37PX-23: 8.780 kg

First-class operator comfort

- Outstanding 360° visibility
- Large TFT colour multi monitor
- Large and quiet pressurized cab
- Easy control with Palm Command Control System joysticks (PCCS)
- Heated air-suspended driver seat positioned close to centre of gravity



Easy maintenance

- Rear-mount radiator with swing-up hydraulic fan
- Monitor with self-diagnostic function
- Simple and convenient access to service points



High reliability and durability

- New Komatsu PLUS undercarriage (standard)
- Modular power train design
- Heavy-plate steel used throughout
- Main frame made with welded and cast parts



Complimentary maintenance program for customers



Komatsu Wireless Monitoring System

Unmatched Visibility and Safety

The best view

A super slant nose gives the D37EX/PX-23 the best visibility of any dozers on the market. This unique feature dramatically increases efficiency and jobsite safety, with operators now always having full view of both the blade and the ripper and of objects close to them. The new cab-forward design, with integrated ROPS/FOPS and large glass windows, provides more room and places the operator closer to the blade, further improving visibility and comfort.

Safe and easy access

For a safer entry and exit – and maximum operator protection, the D37EX/PX-23 includes numerous hand-rails and access steps both inside and outside the cabin. It is also easier to refuel or clean windows, or to reach most service points.





High Productivity & Low Fuel Consumption

New Komatsu engine technology

The powerful and fuel-efficient Komatsu SAA4D95LE-6 engine in the D37EXPX-23 delivers 67,7 kW/ 90,7 HP and is EU Stage IIIB/EPA Tier 4 interim certified. To maximise power, fuel efficiency and emission compliance, it is turbo charged and features direct fuel injection, air-to-air after cooling and cooled EGR.

Highly efficient hydrostatic drive line

The hydrostatic drive line is a key factor in the performance of the D37EX/PX-23 dozer. It supplies high drawbar pull when needed and a highly fuel efficient drive line for grading and precision work. With a choice between two operating modes, the operator can select either “quick-shift” or “variable speed” to match a complete range of applications in the most economic and easy way.



Komatsu Diesel Oxidation Catalyst (KDOC)

A simple and high efficiency diesel oxidation catalyst that eliminates the need for PM regeneration and simplifies the engine control system. It integrates a high performance exhaust noise silencer and helps to reduce engine noise.

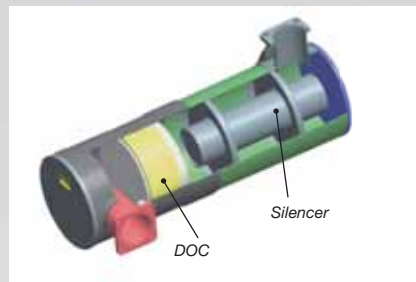

Exhaust Gas Recirculation (EGR)

Cooled EGR is a technology well-proven in current Komatsu engines. The increased capacity of the EGR cooler now ensures very low NOx emissions and a better engine performance.

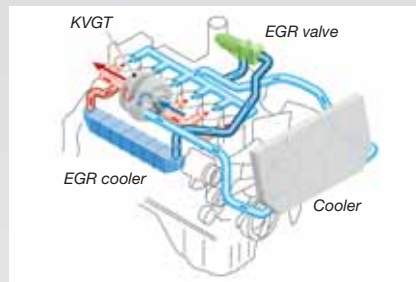

Komatsu Variable Flow Turbocharger (KVFT)

Varies the intake air-flow. The wheel speed of the exhaust turbine is controlled by a valve for optimum air flow to the engine combustion chamber, under any load or speed conditions. The exhaust gas is cleaner, with no reduction in power or performance.

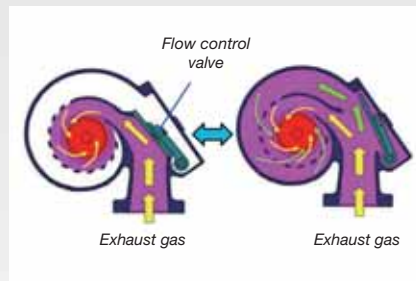

Komatsu Closed Crankcase Ventilation (KCCV)

Crankcase emissions (blow-by gas) are passed through a CCV filter. The oil mist trapped in the filter is returned back to the crankcase while the filtered gas is returned to the air intake.

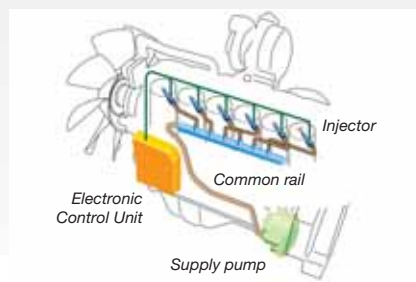

High-Pressure Common Rail (HPCR)

To achieve complete fuel burn and lower exhaust emissions, the heavy duty High-Pressure Common Rail fuel injection system is computer controlled to deliver a precise quantity of pressurised fuel into the redesigned engine combustion chamber by multiple injections.

Hydrostatic transmission (HST) control system

The unique, Komatsu-designed hydrostatic transmission controller monitors the engine output and working equipment or travel load. It controls the HST pumps and motors displacement to deliver optimum speed and drawbar pull. In addition, the controller provides ample power to both tracks when turning, enabling counter rotation at very low speeds and making the D37EX/PX-23 extremely manoeuvrable.



Automatic speed change

Komatsu HST controller always changes the travel speed automatically, depending on load or ground conditions, and efficient operations are facilitated – with no shift shocks. The dozer can work at the optimal speed and drawbar pull point, increasing productivity and fuel efficiency.

Efficient hydrostatic engine cooling fan

The cooling fan always runs at the lowest convenient speed. Rotation and velocity are electronically adjusted based on the temperature of the engine coolant and hydraulic oil. This reduces fuel consumption and operating noise levels, and requires less horsepower than a belt-driven fan.

For extra efficiency, the fan also has a large air outlet surface, and the complete inlet area is protected by a fine grid, to prevent small particles from entering the fan area.

First-Class Operator Comfort

A smooth ride and lower noise levels

The cab on the D37EX/PX-23 was moved forward, and operators now sit closer to the centre of gravity of the machine. With the ripper still easily within eyeshot, they enjoy the best view of the blade, the lowest vibration levels and the highest stability of any dozer on the market. Silicon oil filled cab damper mounts isolate the operator compartment from the machine body and suppress vibrations, providing a quiet, comfortable operating environment. A new unique location for the radiator – at the rear of the machine – and the low speed of the hydraulically driven cooling fan further reduce noise levels.

Pressurised cab

The integrated ROPS/FOPS cab's new design and large, tinted windows ensure excellent visibility in all directions. Superior cab sealing, air filters and raised internal air pressure prevent dust from getting into the cab. In addition, the high-quality interior is lined with sound-absorbent material.

Easy operation control

The ergonomic Palm Command Control System (PCCS) provides efficient and comfortable steering of the machine, and the blade control joystick utilizes Proportional Pressure Control (PPC) for precise operations, excellent and easy grading jobs - and improved productivity.

Large TFT colour multi monitor

A large user-friendly colour monitor enables safe, accurate and smooth work. It provides on-hand data to continuously improve productivity and fuel consumption. Multilingual and with all essential information available at a glance, it features simple and easy to operate switches and multifunction keys that provide the operator with fingertip access to a wide range of functions and operating information.

Fully-adjustable, heated air suspension seat

The driver's seat and console are amongst the most important components of the driver's equipment. The comfortable, heavy-duty, air suspension seat, complete with headrest, gives the operator a secure and comfortable work environment.



Large TFT colour multi monitor



Palm Command Control System (PCCS)



Combined decelerator/brake pedal



Auxiliary input (MP3 jack)



High Reliability and Durability

Low-drive “PLUS” undercarriage

Komatsu’s new low-drive Parallel Link Undercarriage System (PLUS) is extraordinarily tough, with an excellent grading performance and stability. It features PLUS link assemblies, a new highly reliable floating bushing concept, substantial track link height, superior oil seals and newly designed track guards to maximise undercarriage durability. For easier servicing, the equalizer bar’s centre pin can be remotely greased. The segmented sprockets can be changed individually and by hand, so a single mechanic can carry out replacements at the jobsite.

EX undercarriage

The EX undercarriage has been specially designed for working on hard ground. The small to medium-width shoes and PLUS link assembly ensure a large contact area between the machine and the ground for maximum stability, grading performance and undercarriage lifetime.

Modular design

D37EX/PX-23 was designed and manufactured to have low maintenance costs and a long lifetime. This was achieved mainly by reducing component complexity and with a strong modular design.

Improved rigidity and durability

Komatsu’s monocoque track frame uses thicker box section material, and the machine’s main frame is a highly-rigid simple hull with thick plates and steel casting. Both frames have fewer welded components and combine to provide increased strength, rigidity and durability to the D37EX/PX-23.

Self-adjusting idler support

The self-adjusting idler support provides constant and even tension on idler guide plates. It reduces noise levels and vibrations and increases undercarriage life.

PX undercarriage

The PX undercarriage is ideal for working on soft surfaces. The wide shoes and PLUS link assembly ensure a large contact area between the machine and the ground for maximum stability, grading performance and undercarriage lifetime.



Self-adjusting idler support



Modular design

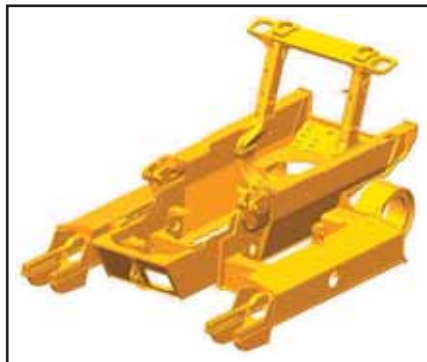

High-rigidity simple hull frame structure



Komatsu Parallel Link Undercarriage System (PLUS)

Easy Maintenance

Simple and convenient service

Well located service doors allow convenient and safer ground access to daily service points. With the radiator located at the rear of the machine, engine fuel and oil filters can be easily accessed from the front of the engine compartment. Remote grease points facilitate lubrication of the C-frame pivots and angle cylinder bearing.

Self-diagnostic monitor

The multi-function monitor panel displays the running time, engine revs, fuel level and water coolant temperature in real time. It also provides the operator with maintenance and service information, if oil filters need replacing or any abnormality occurs. In addition, it supplies Komatsu mechanics with detailed information, with no need for external service tools.

Engine protection

A large, double air filter ensures maximum engine protection. Fuel passes through a pre-filter with a water separator and a special final filter, maximising the engine's lifetime and minimising maintenance costs. The engine cooling fan position at the back of the machine significantly reduces dust levels at the engine air intake. This intake has a rain cap as standard and a turbo type pre cleaner in option for very dusty environments and to lengthen the intervals between the cleaning of the air filters.



Komatsu CARE is a complimentary maintenance program for Komatsu customers that comes as standard with every new Komatsu EU Stage IIIB construction machine. For the first 3 years or 2,000 hours it covers factory-scheduled maintenance, performed by Komatsu-trained technicians with Komatsu Genuine parts.



Unique front-side access



Track roller guard, centre and end section



Reversible swing-up fan

The D37EX/PX-23 includes a swing-up fan with a gas strut-assisted lift locking system to provide easy access to the radiator, oil cooler, and charge air cooler. The operator can switch the hydraulic fan to “cleaning” mode so that it rotates in reverse at full speed to clean the radiators, reducing maintenance costs and improving fuel efficiency.

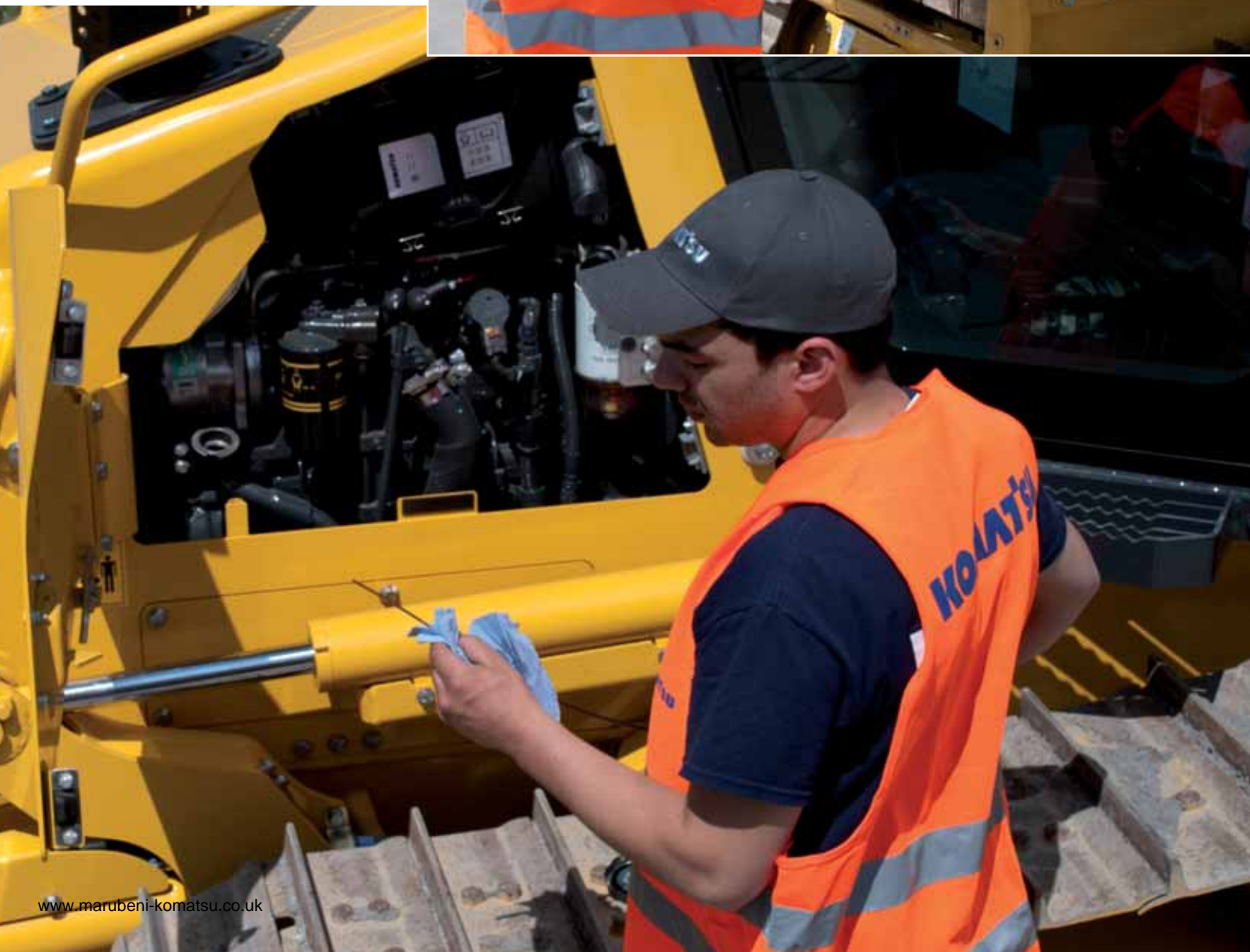

Komatsu Wireless Monitoring System

The easy way to higher productivity

KOMTRAX™ is the latest in wireless monitoring technology. It delivers insightful and cost saving information about your fleet and equipment and offers you a wealth of information to facilitate peak machine performance. By creating a tightly integrated web of support it allows pro active and preventive maintenance and helps you to efficiently run a business.

Knowledge

You get quick answers to basic and critical questions about your machines - what they're doing, when they did it, where they're located, how they can be used more efficiently, and when they need to be serviced. Performance data is relayed by satellite from your machine to your computer and to your local Komatsu distributor - who's readily available for expert analysis and feedback.

Convenience

KOMTRAX™ helps to conveniently manage your fleet on the web, wherever you are. Data is analysed and packaged specifically for easy and intuitive viewing in maps, lists, graphs and charts. You can anticipate the type of service and parts your machines could require, or troubleshoot problems before Komatsu technicians arrive on site.





Power

The detailed information that KOMTRAX™ puts at your fingertips 24 hours a day, 7 days a week gives you the power to make better daily and long-term strategic decisions. You can anticipate problems, customize maintenance schedules, minimize downtime and keep your machines where they belong – working on the job site.

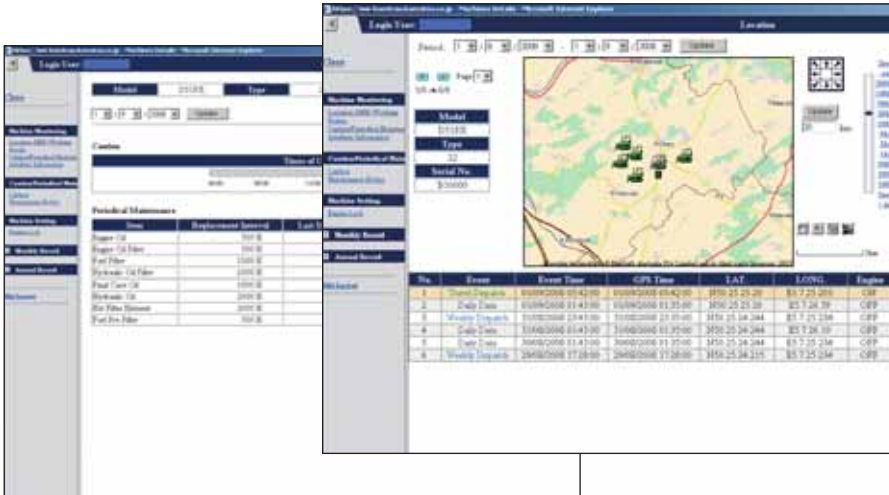

Through the web application, a variety of search parameters are available to quickly find information about specific machines based on key factors such as utilization rates, age, various notification messages, and more.

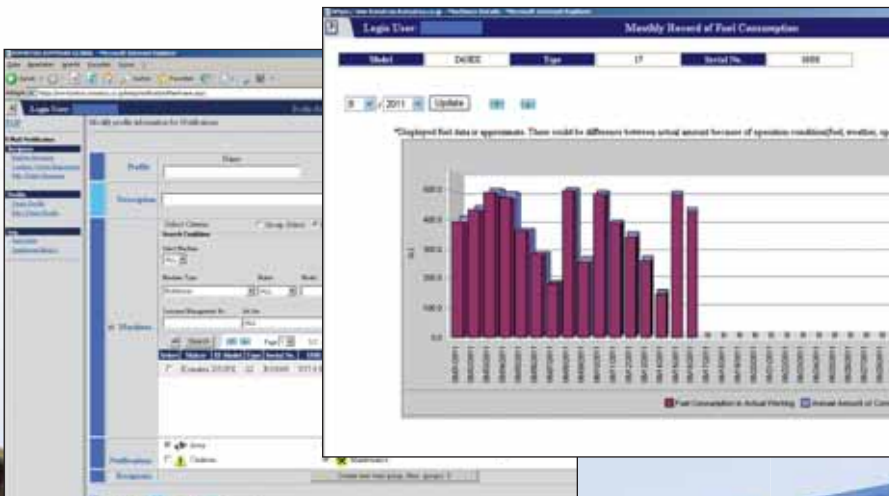

A simple chart shows the machine's fuel consumption and helps you to calculate total costs for a job site and conveniently schedule fuel deliveries.

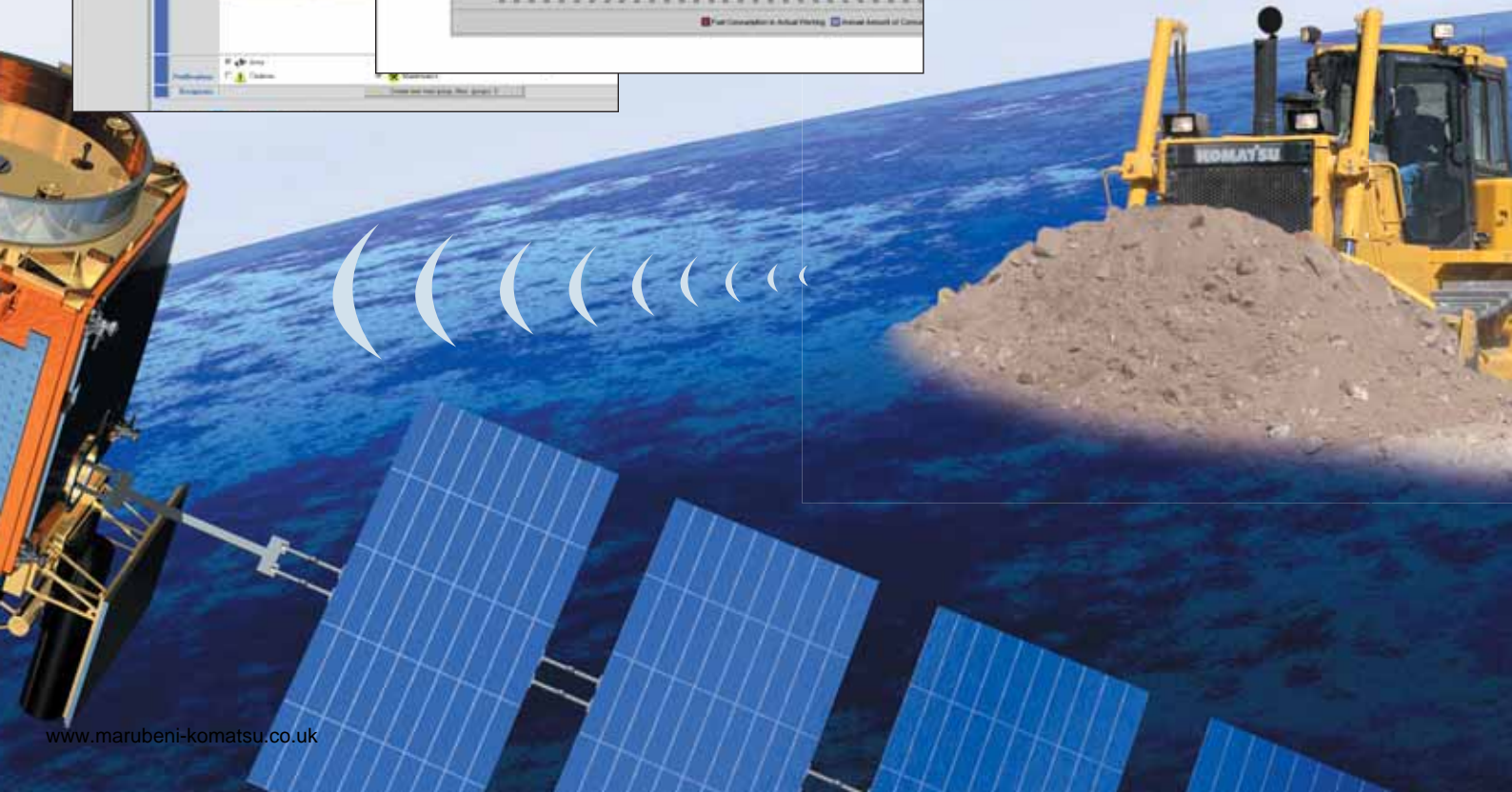

Komatsu blades

Komatsu uses a box blade design, offering the highest resistance for a low weight blade. This increases total blade manoeuvrability and machine balance. High-tensile-strength steel was incorporated into the front and sides of the blade for increased durability. The blade shape design makes it easy to handle a wide range of materials, offering good blade penetration combined with a low blade rolling resistance. Komatsu blades help to deliver excellent fuel efficiency.

Straight Power Angle Tilt blade with adjustable pitch

The straight Power Angle Tilt blade (PAT), offers a wide range of working modes. The new centreball design, with a large ball diameter, offers a strong and durable solution for the blade attachment to the Inpat frame reducing maintenance costs. A fold-up version of the blade for the PX machines guarantees a transport width of 3 metres and easy transportation between job-sites.

Komatsu rippers

Komatsu rippers were designed to combine the highest productivity with a long lifetime. The shank is fitted with special wear parts that increase longevity, and offer the best penetration in various types of materials.

Multishank parallelogram ripper (EX) (option)

The multishank parallelogram ripper has 3 ripper shanks as standard, but can be easily converted to a giant or two-shank ripper, depending on job conditions. The strong parallelogram design offers straight shank movement, adapted for different jobsite applications.

Komatsu-Topcon Plug & Play provisions

The D37-23 comes factory-fitted with “Plug & Play” provisions for the easy installation of Topcon control systems. Specific brackets and plug-in points on the blade, the machine and in the cab allow the quick mounting of all required components. Komatsu-Topcon machine control systems are an ideal way to automate blade movements. All the information from the laser or GPS systems is constantly available on the in-cab display, clearly showing the slope and elevation.

The software is user-friendly and intuitive and greatly reduces the workload by allowing precise and safe operations. Combined with the D37-23 dozer’s high grading efficiency, fuel consumption is reduced to a minimum. Komatsu-Topcon machine control provides high operator satisfaction and gives you the best value for your money.



Straight Power Angle Tilt blade with adjustable pitch



Specifications

ENGINE

Model Komatsu SAA4D95LE-6
 Common rail direct injection, water-cooled, emissionised, turbocharged, after-cooled diesel

Engine power
 at rated engine speed 2.200 rpm
 ISO 14396 67,7 kW/90,7 HP
 ISO 9249 (net engine power) 66,1 kW/88,6 HP

No. of cylinders 4
 Bore x stroke 95 x 115 mm
 Displacement 3,26 ltr
 Governor All-speed, electronic
 Fan drive type Hydraulic
 Lubrication system
 Method Gear pump, force lubrication
 Filter Full flow

HYDROSTATIC TRANSMISSION

Dual-path, hydrostatic transmission provides infinite speed changes up to 8,5 km/h. The variable capacity travel motors allow the operator to select the optimum speed to match specific jobs. Travel control lock lever and neutral switch.

MAX. TRAVEL SPEEDS

Quick shift mode	Forward	Reverse
1st	0 - 3,4 km/h	0 - 4,1 km/h
2nd	0 - 5,6 km/h	0 - 6,5 km/h
3rd	0 - 8,5 km/h	0 - 8,5 km/h

Variable speed mode	Forward	Reverse
	0 - 8,5 km/h	0 - 8,5 km/h

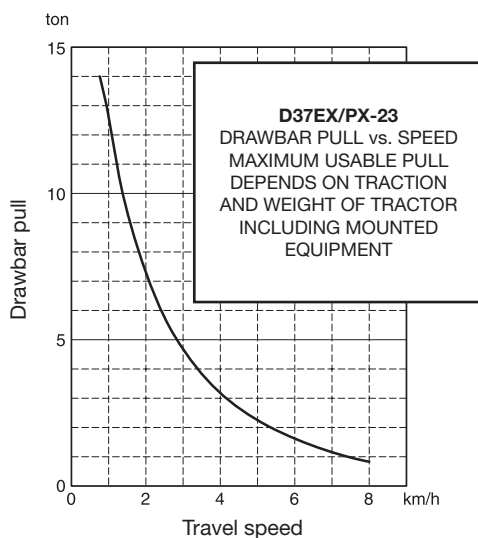

FINAL DRIVE

Type Planetary gear, double-reduction
 Sprocket Bolt-on for easy replacement

STEERING SYSTEM

Type Hydrostatic Steering System (HST)
 Steering control PCCS-lever
 Service brakes Hydraulic dynamic brake, pedal-controlled
 Minimum turning radius (pivot turn)
 D37EX-23 2,1 m
 D37PX-23 2,3 m
 As measured by track marks on the ground.

UNDERCARRIAGE

Suspension Rigid type
 Track roller frame... Monocoque, large section, durable construction
 Tracks PLUS link assembly
 Track tension Combined spring and hydraulic unit
 Number of shoes (each side) 41
 Grouser height (single grouser) 47 mm
 Track rollers (each side) 6
 Shoe width (standard)
 D37EX-23 400 mm
 D37PX-23 600 mm
 Ground contact area
 D37EX-23 17.840 cm²
 D37PX-23 26.760 cm²
 Ground pressure
 D37EX-23 0,47 kg/cm²
 D37PX-23 0,33 kg/cm²
 Including PAT blade, hitch, steel cab, operator, rated capacity of lubricant, coolant, and full fuel tank.

OPERATING WEIGHT (APPR.)

Including PAT blade, hitch, steel cab, operator, rated capacity of lubricant, coolant, and full fuel tank.
 D37EX-23 8.480 kg
 D37PX-23 8.780 kg

SERVICE REFILL CAPACITIES

Cooling system 34 ltr
 Fuel tank 190 ltr
 Engine oil 11 ltr
 Hydraulic tank 64 ltr
 Final drive (each side) 3,5 ltr

ENVIRONMENT

Engine emissions Fully complies with EU Stage IIIB and EPA Tier 4 interim exhaust emission regulations

Noise levels
 LwA external 104 dB(A) (2000/14/EC Stage II)
 LpA operator ear 77 dB(A) (ISO 6396 dynamic test)

Vibration levels (EN 12096:1997)*
 Hand/arm ≤ 2,5 m/s² (uncertainty K = 1,30 m/s²)
 Body ≤ 0,5 m/s² (uncertainty K = 0,29 m/s²)
 * for the purpose of risk assessment under directive 2002/44/EC, please refer to ISO/TR 25398:2006.

DIMENSIONS

	D37EX-23	D37PX-23
A	2.710 mm	3.200 mm
B	370 mm	435 mm
C	865 mm	835 mm
C'	1.075 mm	1.075 mm
D	890 mm	890 mm
E	380 mm	380 mm
F	2.230 mm	2.230 mm
G	4.275 mm	4.275 mm
H	2.785 mm	2.785 mm
I	47 mm	47 mm
J	1.570 mm	1.710 mm
K	400 mm	600 mm
L	1.970 mm	2.310 mm
M	2.510 mm	2.960 mm
N	4.780 mm	4.880 mm
O	2.480 mm	2.905 mm

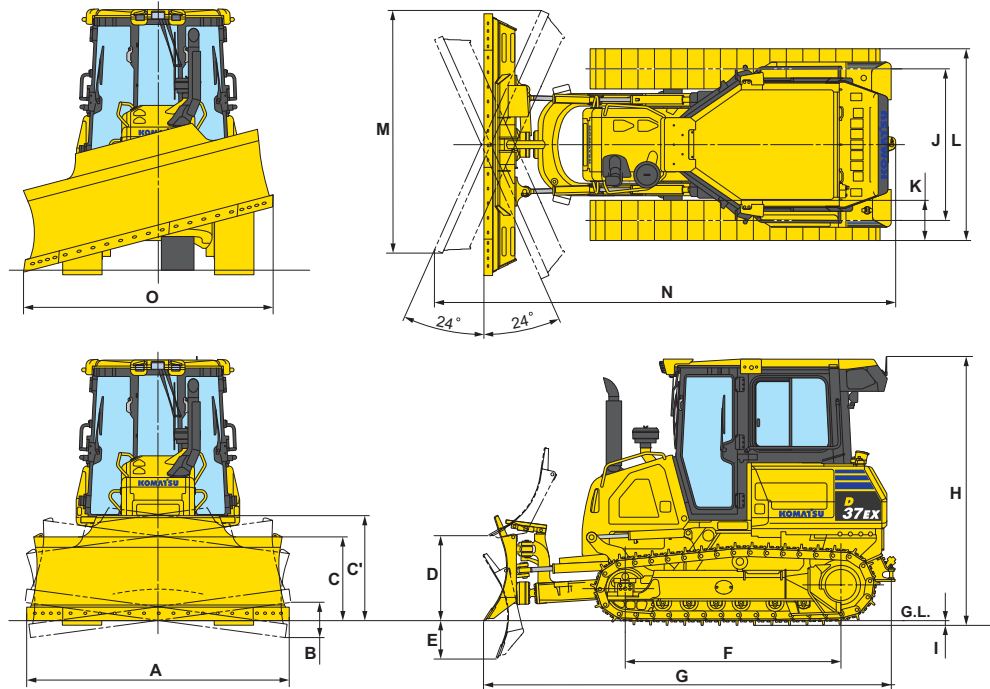

Ground clearance: 325 mm (+ 47 mm grouser height)

HYDRAULIC SYSTEM

Type	CLSS (closed-centre load sensing system)
All spool valves externally mounted beside the hydraulic tank.	
Maximum pump flow	99 ltr/min
Relief valve setting	280 kg/cm ²
Spool control valve positions	
Blade lift	Raise, hold, lower, and float
Blade tilt	Right, hold, and left
Blade angle	Right, hold, and left
Additional control valve positions for ripper	
Ripper lift	Raise, hold, and lower
Hydraulic cylinders	Double-acting, piston type
No. of cylinders × bore	
Blade lift	2 × 75 mm
Blade tilt	1 × 90 mm
Blade angle	2 × 80 mm
Ripper lift	1 × 105 mm

RIPPER EQUIPMENT

Type	Multishank ripper
Type	Hydraulically controlled parallelogram ripper
No. of shanks	3
Weight (including hydraulic control unit)	680 kg
Beam length	1.570 mm
Maximum lift above ground	400 mm
Maximum digging depth	330 mm

DOZER EQUIPMENT

	Overall length with dozer	Blade width × height	Maximum lift above ground	Maximum drop below ground	Maximum tilt adjustment	Blade angle
1,91 m ³ PAT blade (EX)	4.275 mm	2.710 mm × 865 mm	890 mm	380 mm	370 mm	24°
2,13 m ³ PAT blade (PX)	4.275 mm	3.200 mm × 835 mm	890 mm	380 mm	435 mm	24°
1,95 m ³ narrow PAT blade (PX)	4.275 mm	2.875 mm × 835 mm	890 mm	380 mm	390 mm	24°

Blade capacities are based on the SAE recommended practice J1265.

Crawler Dozer

D37EX/PX-23

Standard and Optional Equipment

ENGINE AND RELATED PARTS

Komatsu SAA4D95LE-6 turbocharged common rail direct injection diesel engine	●
EU Stage IIIB/EPA Tier 4 interim compliant	●
Fuel pre-filter (10 micron) and fuel filter (2 micron)	●
Exhaust pipe with elbow	●
Intake pipe with rain cap	●
Engine cooling fluid corrosion resistor	●
Alternator 24 V/60 A	●
Starter motor 4,5 kW/24 V	●
Batteries 92 Ah/2 × 12 V	●
Fuel tank inlet strainer	●
Intake pipe with air pre-cleaner	○

TRANSMISSION AND BRAKES

Electronically controlled HST	●
Palm lever steering control (PCCS)	●
Quick shift selection system	●
Variable speed mode	●
Reverse speed presets	●
Combined decelerator/brake pedal	●

UNDERCARRIAGE

Single grouser heavy-duty shoes (EX: 400 mm; PX: 600 mm)	●
Komatsu PLUS link assembly	●
Track roller guard, centre and end section	●
Full length track roller guard	○
Single grouser heavy-duty shoes 460 mm (EX)	○

LIGHTING SYSTEM

Working lights, 3 cab roof front, 2 cab roof rear	●
---	---

SERVICE AND MAINTENANCE

Swing-out hydrostat-driven radiator fan with reversing function	●
Dry type air cleaner, double element with dust indicator and evacuator	●
Water separator	●
Multi-function video compatible colour monitor with Equipment Management and Monitoring System (EMMS) and efficiency guidance	●
KOMTRAX™ – Komatsu wireless monitoring system	●
Komatsu CARE	●
Tool kit	●

CABIN

Air suspension seat: fabric, reclining, heated, high backrest	●
Seat belt with visible alert	●
High mount footrest	●
Air conditioner	●
Radio	●
Auxiliary input (MP3 jack)	●
2 × 12 Volt power supply (120 W)	●
1 × 24 Volt power supply	●
Viscous cab mounts	●
Rear-view mirror (inside cab)	●
Wiper front window	●
Wiper rear window	●
Wipers doors	●
Cup holder	●

HYDRAULIC SYSTEM

Hydraulics for dozing blades	●
Mono lever blade control	●
Hydraulics for ripper	○

SAFETY EQUIPMENT

Steel cab, meets ISO 3471 and SAE J1040, APR88 ROPS standards, as well as ISO 3449 FOPS standards	●
Horn	●
Locks, filter caps and covers	●
Back-up alarm	●
Rear view camera system	●
Fire extinguisher	○

ATTACHMENTS

Front pull hook	●
Hitch (not with ripper)	●

DOZER EQUIPMENT

1,91 m ³ PAT blade (EX)	○
2,13 m ³ PAT blade (PX)	○
1,95 m ³ narrow PAT blade (PX)	○
Multishank parallelogram ripper (EX only)	○

AUTOMATIC MACHINE CONTROL

Komatsu-Topcon Plug & Play provisions	●
Komatsu-Topcon machine control systems	○

Further equipment on request

- standard equipment
- optional equipment

Your Komatsu partner:

UK Distributor:

Marubeni-Komatsu Ltd
Redditch
Worcestershire
B98 0RT

01527 512 512

EENSS20060 07/2013

Materials and specifications are subject to change without notice.

KOMATSU is a trademark of Komatsu Ltd. Japan.

KOMATSU

**Komatsu Europe
International NV**
Mechelsesteenweg 586
B-1800 VILVOORDE (BELGIUM)
Tel. +32-2-255 24 11
Fax +32-2-252 19 81
www.komatsu.eu