

SPECIFICATIONS HD325-7



ENGINE

Model.....Komatsu SAA6D140E-5
 Type..... Common rail direct injection, water-cooled, turbocharged, after-cooled, cooled EGR diesel
 Engine power
 at rated engine speed2.000 rpm
 ISO 14396.....386 kW / 518 HP
 ISO 9249 (net engine power).....371 kW / 498 HP
 No. of cylinders 6
 Bore x stroke 140 x 165 mm
 Displacement..... 15,24 ltr
 Max. torque.....2.167 Nm/221 kgf-m
 Governor..... Electronically controlled
 Lubrication system:
 Lubrication method Gear pump, force lubrication
 Filter Full flow
 Air filter Dry type with double elements and precleaner (cyclonpack type), plus dust indicator



TRANSMISSION

Torque converter..... 3-elements, 1-stage, 2-phase
 Transmission..... Full-automatic, planetary type
 Speed range 7 speeds forward and 1 reverse
 Lock-up clutch Wet, multiple-disc clutch
 Forward Torque converter drive in 1st gear, direct drive in 1st lockup and all higher gears
 Reverse Torque converter drive
 Shift control..... Electronic shift control with automatic clutch modulation in all gears
 Max. travel speed..... 70 km/h



AXLES

Final drive type Planetary gear
 Rear axle Full floating
 Ratios:
 Differential 3,125
 Planetary..... 4,737



SUSPENSION

Independent, hydropneumatic suspension cylinder with fixed throttle to dampen vibration.
 Effective cylinder stroke:
 Front suspension250 mm
 Rear suspension..... 129 mm
 Rear axle oscillation:
 Oil stopper..... 6,8°
 Mechanical stopper..... 8,1°



STEERING SYSTEM

Type.....Fully hydraulic power steering with two double-acting cylinders
 Supplementary steering Automatically and manually controlled (meets ISO 5010, SAE J1511 and SAE J53)
 Minimum turning radius, centre of front tyre 7,2 m
 Maximum steering angle (outside tyre)43°



BRAKES

Brakes meet ISO 3450 and SAE J1473 standards.
 Service brakes:
 Front..... Full-hydraulic control, caliper disc type
 Rear Full-hydraulic control, oil-cooled multiple-disc type
 Parking brake..... Spring applied, multiple-disc type
 Retarder..... Oil-cooled, multiple-disc rear brakes act as retarder.
 Retarder capacity (continuous)..... 662 kW / 887 HP
 Secondary brake A relay valve automatically actuates the service brakes when hydraulic pressure drops below the rated level. Manual operation is also possible.
 Brake surface:
 Front..... 968 cm²
 Rear 50.847 cm²



HYDRAULIC SYSTEM

Hoist cylinder Twin, 2-stage telescopic type
 Relief pressure 20,6 MPa/210 kg/cm²
 Hoist time (at high idle).....10 sec
 Lowering time (float)10 sec



CAB

Dimensions comply with ISO 3471 and SAE J1040-1988c ROPS (Roll-Over Protective Structure) standards and ISO 3449 and SAE J231 FOPS (Falling Object Protective Structure) standard.



MAIN FRAME

Type Box-sectioned construction



TYRES

Standard tyres 18.00 R33



BODY

Capacity:

Struck.....	18,0 m ³
Heaped (3:1).....	21,5 m ³
Heaped (2:1, SAE).....	24,0 m ³
Payload.....	36,5 metric tons
Material.....	130 kg/mm ²
	400 Brinell high tensile strength steel

Material thickness:

Bottom.....	19 mm
Front.....	12 mm
Sides.....	9 mm

Target area (inside length x width) 5.500 mm x 3.380 mm
 Dumping angle 48°
 Height at full dump..... 8.070 mm
 Heating Exhaust heating



WEIGHT (APPROX.)

Empty weight.....	33.400 kg
Gross vehicle weight	69.900 kg
Not to exceed max. gross vehicle weight, including options, fuel and payload.	
Weight distribution	
Empty:	
Front axle	54,2%
Rear axle.....	45,8%
Loaded:	
Front axle	34,6%
Rear axle.....	65,4%



ENVIRONMENT

Engine emissions Fully complies with EU Stage IIIA and EPA Tier III exhaust emission regulations

Noise levels:

 LpA operator ear 78 dB(A) (ISO 6396 dynamic test)

 LwA external 110 dB(A) (2000/14/EC Stage II)

Vibration levels (EN 12096:1997)*

 Hand/arm ≤ 2,5 m/s² (uncertainty K = 0,68 m/s²)

 Body..... ≤ 0,5 m/s² (uncertainty K = 0,29 m/s²)

* for the purpose of risk assessment under directive 2002/44/EC, please refer to ISO/TR 25398:2006.



SERVICE REFILL CAPACITIES

Fuel tank.....	484 ltr
Engine oil.....	50 ltr
Torque converter, transmission and retarder cooling.....	90 ltr
Differentials (total)	45 ltr
Final drives (total)	30 ltr
Hydraulic system	129 ltr
Suspension (total).....	44,2 ltr



MACHINE DIMENSIONS HD325-7

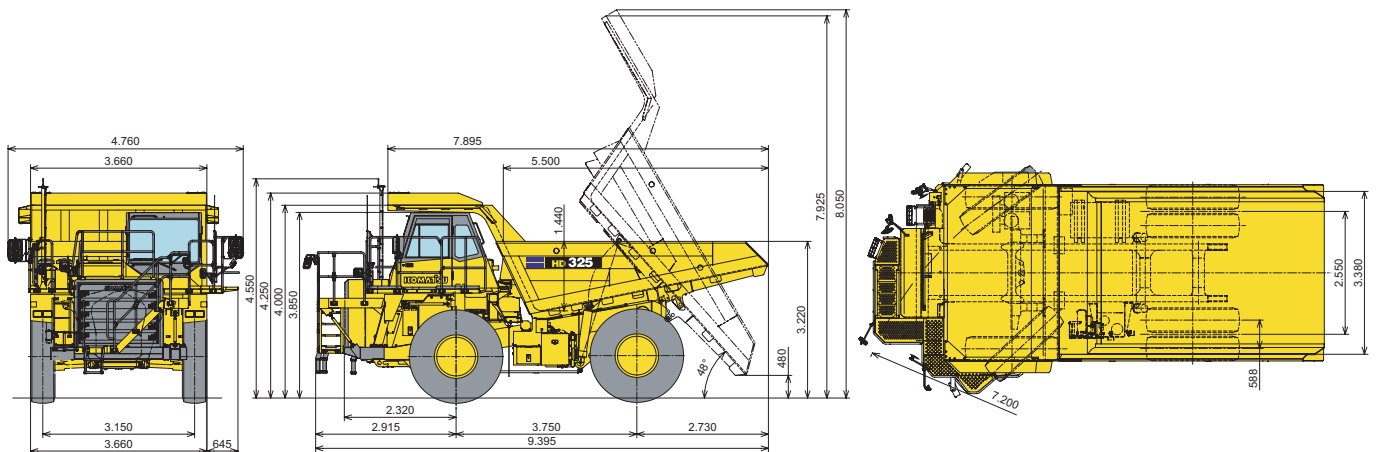

TRAVEL PERFORMANCE

To determine travel performance:
 Read from gross weight down to the percent of total resistance. From this weight-resistance point, read horizontally to the curve with the highest obtainable speed range, then down to maximum speed. Usable rimpull depends upon traction available and weight on drive wheels.

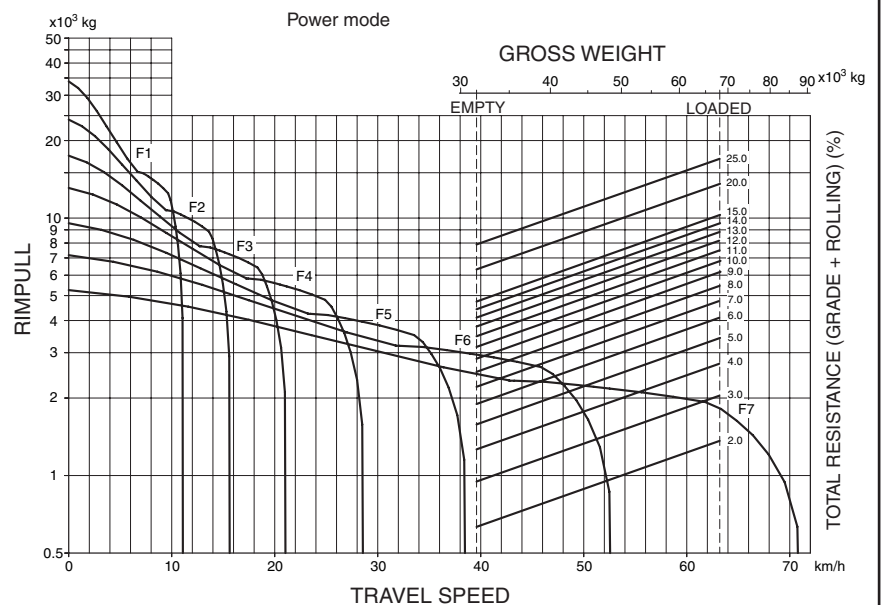

RETARDER PERFORMANCE

To determine brake performance:
 These curves are provided to establish the maximum speed and gearshift position for safer descents on roads with a given distance. Read from gross weight down to the percent of total resistance. From this weight-resistance point, read horizontally to the curve with the highest obtainable speed range, then down to maximum descent speed the brakes can safely handle without exceeding cooling capacity.

GRADE DISTANCE: CONTINUOUS DESCENT

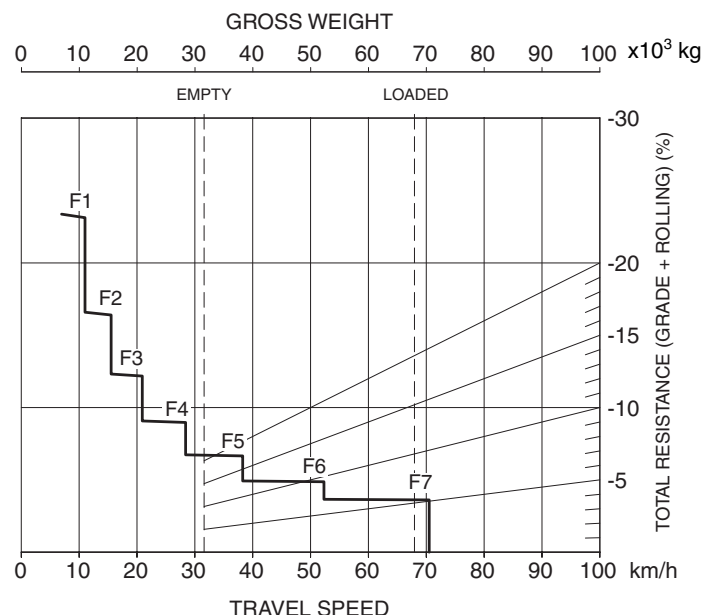

GRADE DISTANCE: 450 m

GRADE DISTANCE: 600 m

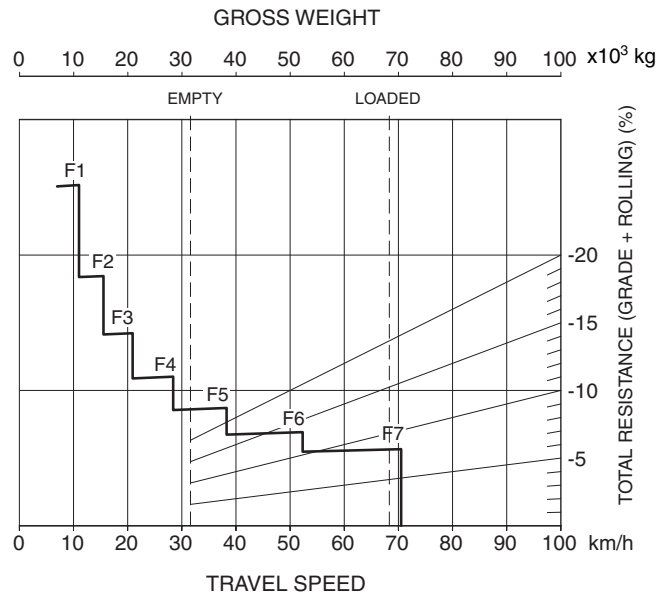
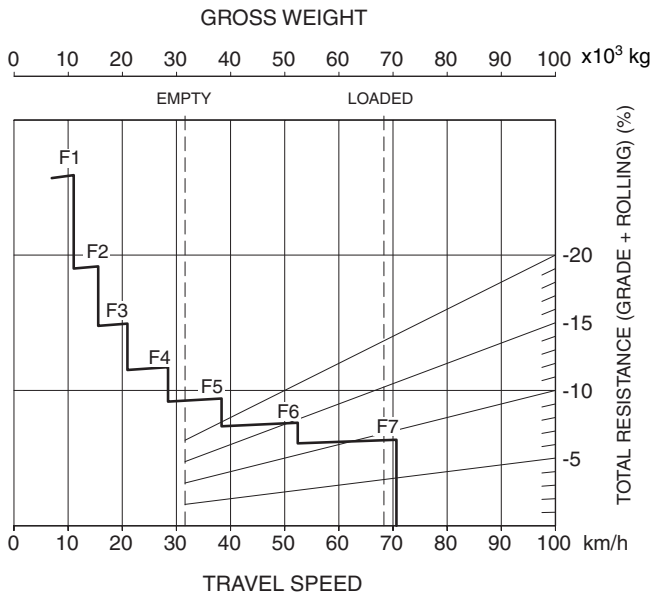

GRADE DISTANCE: 900 m

GRADE DISTANCE: 1.500 m

