

SPECIFICATIONS HD465-7



ENGINE

Model Komatsu SAA6D170E-5
 Type Common rail direct injection, water-cooled, turbocharged, after-cooled, cooled EGR diesel
 Engine power
 at rated engine speed 2.000 rpm
 ISO 14396 552 kW / 740 HP
 ISO 9249 (net engine power) 533 kW / 715 HP
 No. of cylinders 6
 Bore x stroke 170 x 170 mm
 Displacement 23,15 ltr
 Max. torque 3.324 Nm/339 kgf-m
 Governor Electronically controlled
 Lubrication system:
 Lubrication method Gear pump, force lubrication
 Filter Full flow
 Air filter Dry type with double elements and precleaner (cyclonpack type), plus dust indicator



TRANSMISSION

Torque converter 3-elements, 1-stage, 2-phase
 Transmission Full-automatic, planetary type
 Speed range 7 speeds forward and 1 reverse
 Lock-up clutch Wet, multiple-disc clutch
 Forward Torque converter drive in 1st gear, direct drive in 1st lockup and all higher gears
 Reverse Torque converter drive
 Shift control Electronic shift control with automatic clutch modulation in all gears
 Max. travel speed 70 km/h



AXLES

Final drive type Planetary gear
 Rear axle Full floating
 Ratios:
 Differential 3,538
 Planetary 4,737



SUSPENSION

Independent, hydropneumatic suspension cylinder with fixed throttle to dampen vibration.
 Effective cylinder stroke:
 Front suspension 303 mm
 Rear suspension 140 mm
 Rear axle oscillation:
 Oil stopper 6,8°
 Mechanical stopper 7,7°



STEERING SYSTEM

Type Fully hydraulic power steering with two double-acting cylinders
 Supplementary steering Automatically and manually controlled (meets ISO 5010, SAE J1511 and SAE J53)
 Minimum turning radius, centre of front tyre 8,5 m
 Maximum steering angle (outside tyre) 39°



BRAKES

Brakes meet ISO 3450 and SAE J1473 standards.
 Service brakes:
 Front Full-hydraulic control, caliper disc type
 Rear Full-hydraulic control, oil-cooled multiple-disc type
 Parking brake Spring applied, multiple-disc type
 Retarder Oil-cooled, multiple-disc rear brakes act as retarder.
 Retarder capacity (continuous) 785 kW / 1.052 HP
 Secondary brake A relay valve automatically actuates the service brakes when hydraulic pressure drops below the rated level.
 Manual operation is also possible.
 Brake surface:
 Front 1.936 cm²
 Rear 64.230 cm²



HYDRAULIC SYSTEM

Hoist cylinder Twin, 2-stage telescopic type
 Relief pressure 20,6 MPa/210 kg/cm²
 Hoist time (at high idle) 11,5 sec
 Lowing time (float) 10,5 sec



CAB

Dimensions comply with ISO 3471 and SAE J1040-1988c ROPS (Roll-Over Protective Structure) standards and ISO 3449 and SAE J231 FOPS (Falling Object Protective Structure) standard.



MAIN FRAME

Type Box-sectioned construction



TYRES

Standard tyres 24.00 R35

MACHINE DIMENSIONS HD465-7

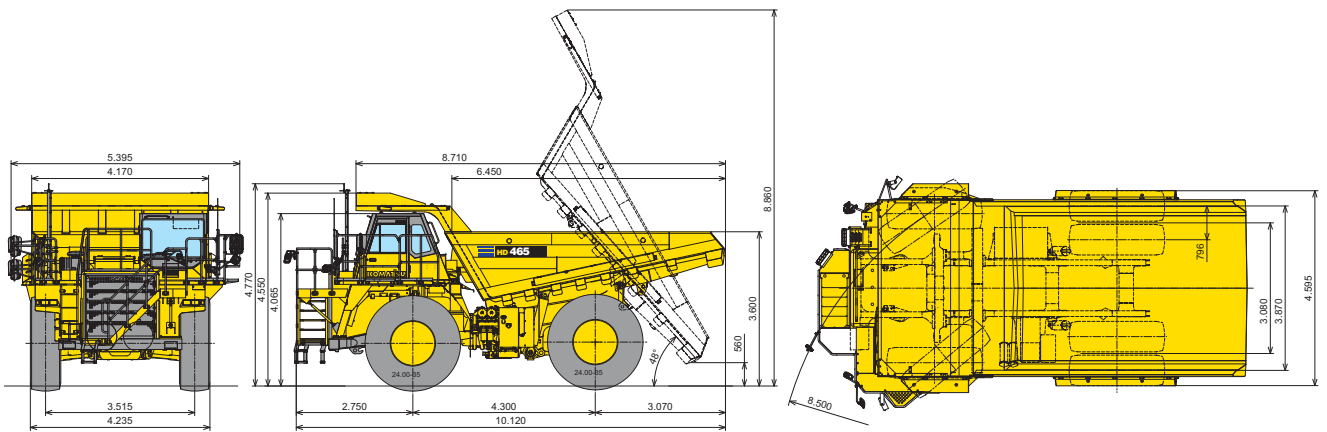

TRAVEL PERFORMANCE

To determine travel performance:
 Read from gross weight down to the percent of total resistance. From this weight-resistance point, read horizontally to the curve with the highest obtainable speed range, then down to maximum speed. Usable rimpull depends upon traction available and weight on drive wheels.

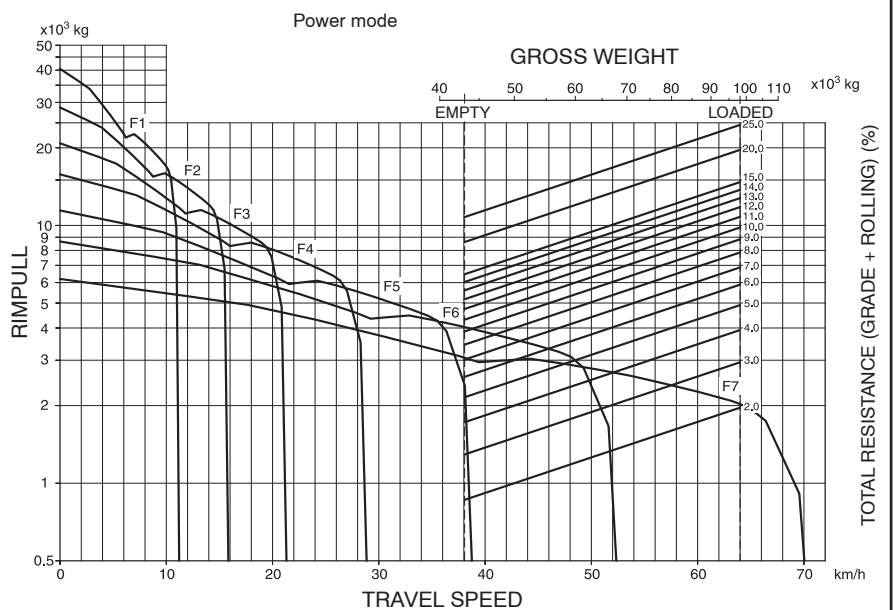

RETARDER PERFORMANCE

To determine brake performance:
 These curves are provided to establish the maximum speed and gearshift position for safer descents on roads with a given distance. Read from gross weight down to the percent of total resistance. From this weight resistance point, read horizontally to the curve with the highest obtainable speed range, then down to maximum descent speed the brakes can safely handle without exceeding cooling capacity.

GRADE DISTANCE: CONTINUOUS DESCENT

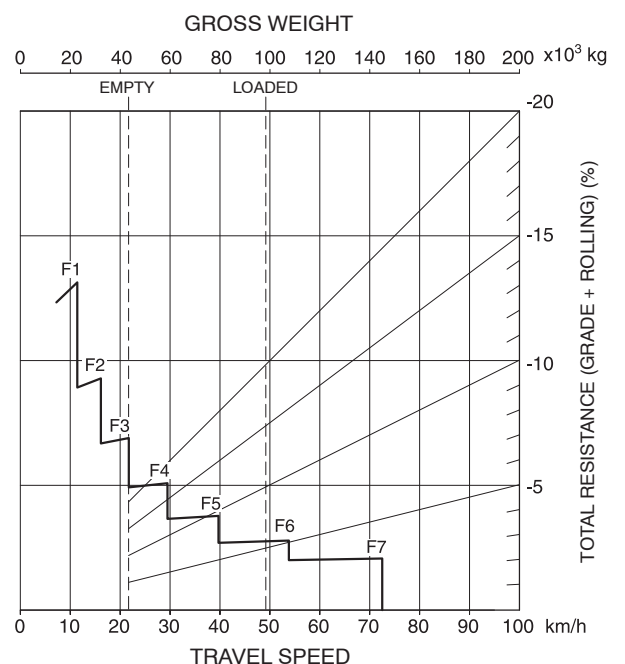

GRADE DISTANCE: 450 m

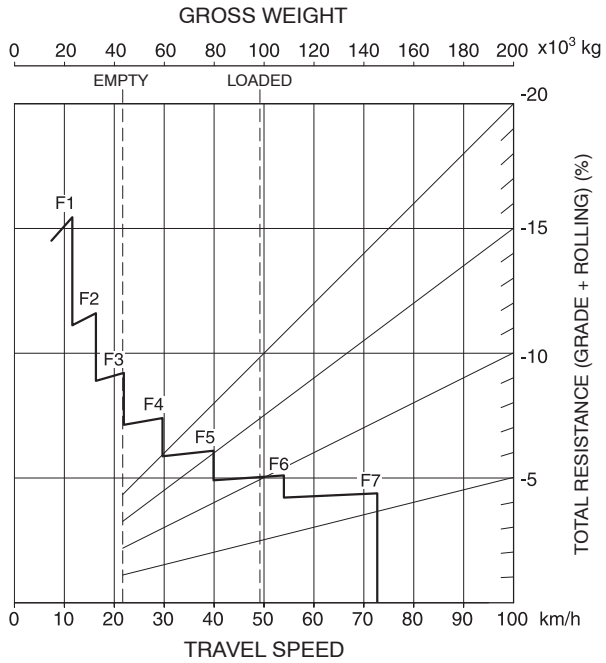

GRADE DISTANCE: 600 m

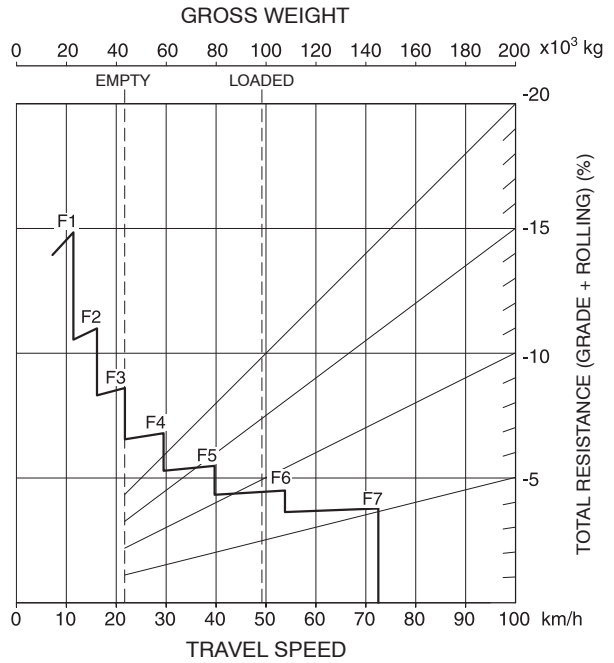

GRADE DISTANCE: 900 m

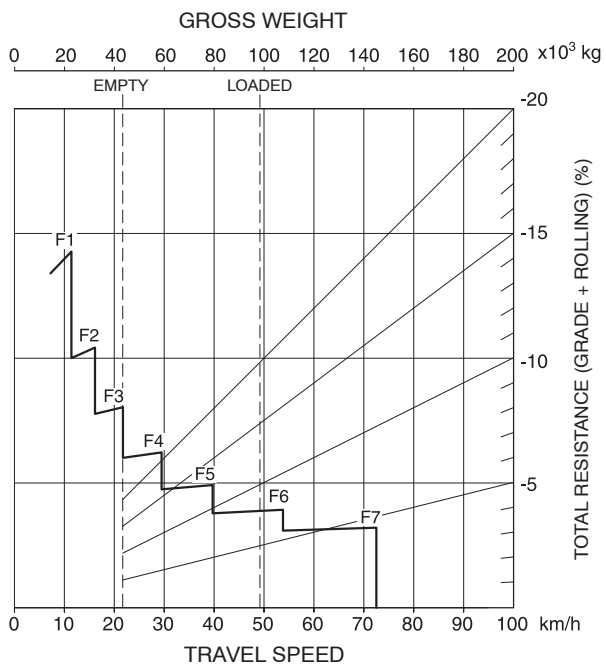

GRADE DISTANCE: 1.500 m

