

# Specifications

## ENGINE

Model ..... Komatsu 4D98E-3ZSFB  
Type ..... low emission, direct injection  
Displacement ..... 3.318 cm<sup>3</sup>  
Bore × stroke ..... 98 mm × 110 mm  
No. of cylinders ..... 4  
Engine power  
at rated engine speed ..... 2.200 rpm  
ISO 14396 ..... 47,4 kW / 63,6 HP  
SAE J1349 ..... 45,6 kW / 61,2 HP  
Max. torque/engine speed ..... 237 Nm/1.400 rpm

## OPERATING WEIGHT

Operating weight, including 1.650 mm arm, 0,20 m<sup>3</sup> bucket (ISO 7451), blade, operator, liquids, filled tank and standard equipment (ISO 6016).

Shoes	Width	Operating weight Mono boom
Steel (450 mm)	2.250 mm	7.618 kg
Steel (600 mm)	2.400 mm	7.800 kg
Rubber (450 mm)	2.250 mm	7.530 kg
Roadliner (450 mm)	2.250 mm	7.636 kg

## TRANSMISSION

Steering control ..... 2 levers with pedals  
Transmission ..... hydrostatic  
Hydraulic motors ..... variable displacement, axial piston  
Max. drawbar pull ..... 6.471 daN (6.600 kg)  
Max. travel speeds Lo / Hi ..... 2,9 km/h - 4,9 km/h  
Parking brake ..... mechanical discs

## UNDERCARRIAGE

Track tensioning ..... grease  
Shoes (each side) ..... 39  
Carrier rollers (each side) ..... 1  
Track rollers (each side) ..... 5  
Ground pressure ..... 0,34 kg/cm<sup>2</sup>

## BLADE

Width × height ..... 2.250 × 400 mm  
Max. lifting above ground level ..... 525 mm  
Max. depth below ground level ..... 460 mm

## HYDRAULIC SYSTEM

Type ..... Komatsu „CLSS“  
Power modes ..... 2 (Power/Economy)  
Main pumps:  
Pump for ..... boom, arm, bucket and travelling  
Type ..... variable displacement, axial piston  
Max. flow ..... 178 ltr/min  
Pump for ..... swing and blade  
Type ..... fixed displacement gear pump  
Max. flow ..... 72 ltr/min  
Auxiliary hydraulic flow (optional) ..... 145 ltr/min  
Relief valve setting:  
Swing and blade ..... 20,0 MPa (204 kg/cm<sup>2</sup>)  
Travel and work equipment ..... 26,5 MPa (270 kg/cm<sup>2</sup>)  
Bucket breakout force (ISO 6015) ..... 5.855 daN (5.970 kgf)  
Arm breakout force, 1.650 mm arm  
(ISO 6015) ..... 3.913 daN (3.990 kgf)

## SWING SYSTEM

Driven by ..... hydraulic motor  
Swing reduction gear ..... with double epicyclic reduction  
Swing circle lubrication ..... grease-bathed  
Swing brakes ..... automatic, with oil immersed discs  
Swing speed ..... 10,2 rpm

## ELECTRIC SYSTEM

Voltage ..... 12 V  
Battery ..... 120 Ah  
Alternator ..... 80 A  
Starter motor ..... 3 kW

## SERVICE CAPACITIES

Fuel tank ..... 110 ltr  
Cooling system ..... 18 ltr  
Engine oil ..... 12,5 ltr  
Hydraulic oil tank ..... 65 ltr

## CAB

Sound-proof cab, provided with safety glasses, liftable windscreen, roof window with protection grid, sliding door with lock, windscreen-wiper, electric horn, adjustable seat with double slide, control system and instrumentation, adjustable joysticks. Outside air inlet.

## ENVIRONMENT

Vibration levels (EN 12096:1997)\*  
Hand/arm ..... ≤ 2,5 m/s<sup>2</sup> (uncertainty K = 1,2 m/s<sup>2</sup>)  
Body ..... ≤ 0,5 m/s<sup>2</sup> (uncertainty K = 0,2 m/s<sup>2</sup>)

\* for the purpose of risk assessment under directive 2002/44/EC, please refer to ISO/TR 25398:2006.

## DIMENSIONS

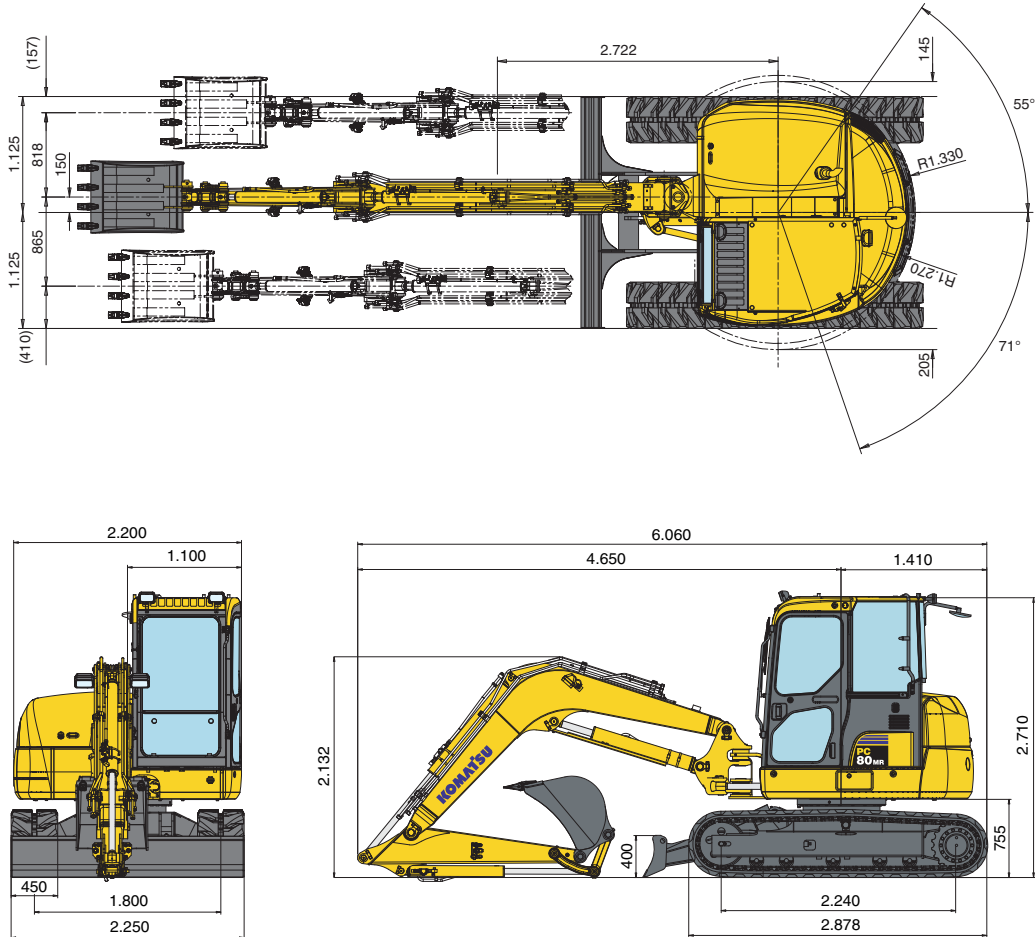

Bucket capacity (ISO 7451)	m <sup>3</sup>	0,086	0,128	0,171	0,2	0,232	0,265
Bucket width	mm	300	400	500	600	700	800
Bucket weight	kg	120	130	142	155	168	180

# Working Range

## MONO BOOM

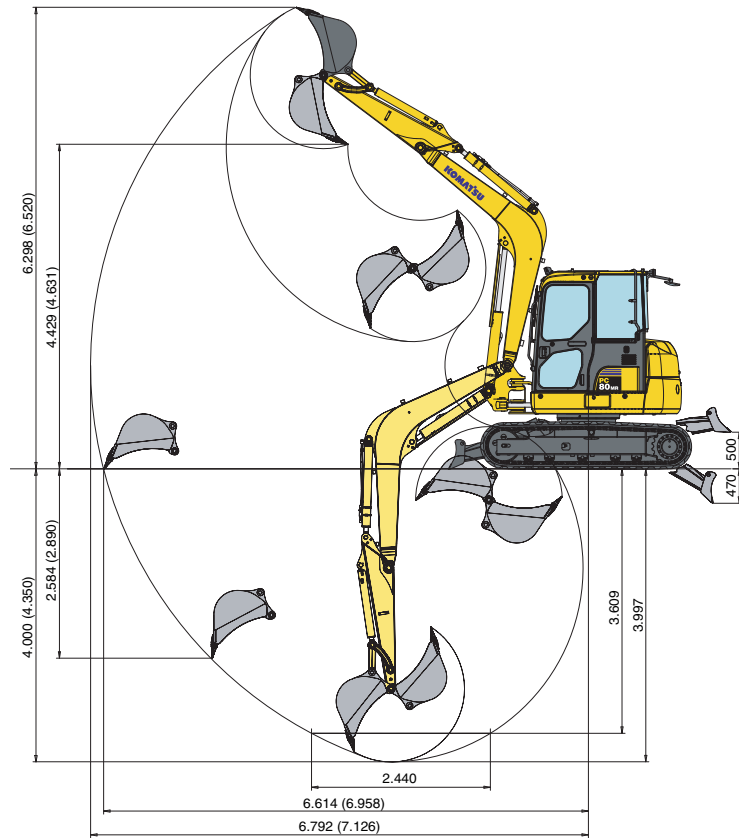

## TWO-PIECE BOOM

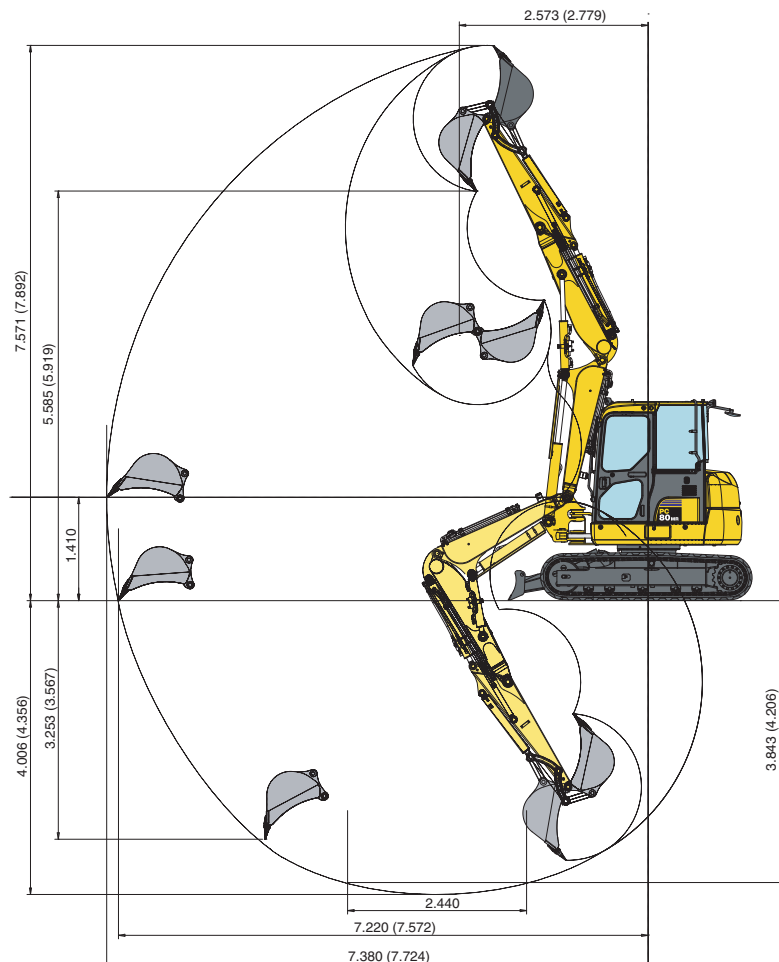

## LIFTING CAPACITY MONO BOOM / WITH BLADE AT GROUND LEVEL

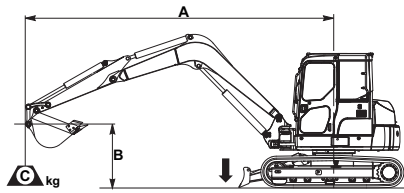

A – Reach from swing centre

B – Bucket hook height

C – Lifting capacities, including bucket (175 kg), bucket linkage and bucket cylinder

– Rating over front

– Rating over side

– Rating at maximum reach

When removing bucket, linkage or cylinder, lifting capacities can be increased by their respective weights.

Arm length	B	A	Additional counterweight			5,0 m		4,0 m		3,0 m	
1.650 mm	4,5 m	---	---	*1.560	1.090	---	---	*1.470	*1.460	*1.300	*1.300
	3,0 m	---	---	*1.580	770	*1.600	940	*1.770	1.390	*2.180	*2.180
	1,5 m	---	---	*1.640	680	*1.890	880	*2.480	1.260	*3.640	1.930
	0,0 m	---	---	*1.730	710	*2.050	840	*2.840	1.180	*4.260	1.830
	-1,5 m	---	---	*1.830	910	---	---	*2.510	1.180	*3.700	1.850
1.650 mm	4,5 m	+ 230 kg	+ 230 kg	*1.560	1.140	---	---	*1.470	*1.460	*1.300	*1.300
	3,0 m	+ 230 kg	+ 230 kg	*1.580	820	*1.600	990	*1.770	1.460	*2.180	*2.180
	1,5 m	+ 230 kg	+ 230 kg	*1.640	720	*1.890	940	*2.480	1.330	*3.640	2.040
	0,0 m	+ 230 kg	+ 230 kg	*1.730	750	*2.050	890	*2.840	1.250	*4.260	1.930
	-1,5 m	+ 230 kg	+ 230 kg	*1.830	960	---	---	*2.510	1.250	*3.700	1.960
2.000 mm	4,5 m	---	---	*1.400	930	*1.380	950	*1.200	*1.200	*900	*900
	3,0 m	---	---	*1.330	680	*1.440	950	*1.540	1.410	*1.690	*1.690
	1,5 m	---	---	*1.410	610	*1.770	890	*2.290	1.280	*3.670	1.990
	0,0 m	---	---	*1.580	630	*2.020	830	*2.790	1.170	*4.300	1.820
	-1,5 m	---	---	*1.690	780	*1.840	820	*2.640	1.150	*3.960	1.820
2.000 mm	4,5 m	+ 230 kg	+ 230 kg	*1.400	980	*1.380	1.010	*1.200	1.200	*900	*900
	3,0 m	+ 230 kg	+ 230 kg	*1.330	730	*1.440	1.000	*1.540	1.480	*1.690	*1.690
	1,5 m	+ 230 kg	+ 230 kg	*1.410	650	*1.770	940	*2.290	1.350	*3.670	2.090
	0,0 m	+ 230 kg	+ 230 kg	*1.580	670	*2.020	880	*2.790	1.240	*4.300	1.920
	-1,5 m	+ 230 kg	+ 230 kg	*1.690	830	*1.840	870	*2.640	1.220	*3.960	1.920

Ratings are based on ISO standard 10567. Rated loads do not exceed 87% of hydraulic lift capacity or 75% of tipping load. Excavators used in object handling operations must comply with the related local regulations and must be equipped with hose burst valves (boom & arm) and an overload warning device in compliance with EN474-5.

- The values marked with an asterisk (\*) are limited by the hydraulic capacities
- Calculations are based on the machine resting on a uniform and firm surface
- The lifting point is a hypothetical hook placed behind the bucket.

# Lifting Capacity

## LIFTING CAPACITY MONO BOOM / WITH BLADE UP

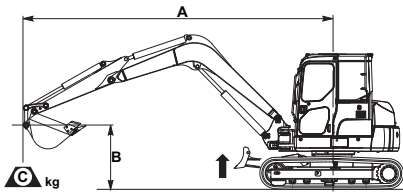

A – Reach from swing centre

B – Bucket hook height

C – Lifting capacities, including bucket (175 kg), bucket linkage and bucket cylinder

– Rating over front

– Rating over side

– Rating at maximum reach

When removing bucket, linkage or cylinder, lifting capacities can be increased by their respective weights.

Arm length	A B	Additional counterweight			5,0 m		4,0 m		3,0 m	
1.650 mm	4,5 m	---	1.330	1.090	---	---	*1.470	*1.460	*1.300	*1.300
	3,0 m	---	960	770	1.160	940	1.720	1.390	*2.180	*2.180
	1,5 m	---	850	680	1.100	880	1.580	1.260	2.480	1.930
	0,0 m	---	890	710	1.050	840	1.490	1.180	2.370	1.830
	-1,5 m	---	1.130	910	---	---	1.490	1.180	2.400	1.850
1.650 mm	4,5 m	+ 230 kg	1.400	1.140	---	---	*1.470	*1.460	*1.300	*1.300
	3,0 m	+ 230 kg	1.010	820	1.210	990	1.770	1.460	*2.180	*2.180
	1,5 m	+ 230 kg	900	720	1.160	940	1.660	1.330	2.600	2.040
	0,0 m	+ 230 kg	930	750	1.110	890	1.560	1.250	2.460	1.930
	-1,5 m	+ 230 kg	1.190	960	---	---	1.560	1.250	2.510	1.960
2.000 mm	4,5 m	---	1.140	930	1.170	950	*1.200	*1.200	*900	*900
	3,0 m	---	850	680	1.170	950	*1.540	1.410	*1.690	*1.690
	1,5 m	---	770	610	1.100	890	1.590	1.280	2.550	1.990
	0,0 m	---	790	630	1.030	830	1.480	1.170	2.350	1.820
	-1,5 m	---	980	780	1.030	820	1.460	1.150	2.350	1.820
2.000 mm	4,5 m	+ 230 kg	1.190	980	1.230	1.010	*1.200	*1.200	*900	*900
	3,0 m	+ 230 kg	900	730	1.220	1.000	*1.540	1.480	*1.690	*1.690
	1,5 m	+ 230 kg	810	650	1.160	940	1.670	1.350	2.660	2.090
	0,0 m	+ 230 kg	840	670	1.100	880	1.560	1.240	2.470	1.920
	-1,5 m	+ 230 kg	1.030	830	1.090	870	1.530	1.220	2.470	1.920

Ratings are based on ISO standard 10567. Rated loads do not exceed 87% of hydraulic lift capacity or 75% of tipping load. Excavators used in object handling operations must comply with the related local regulations and must be equipped with hose burst valves (boom & arm) and an overload warning device in compliance with EN474-5.

- The values marked with an asterisk (\*) are limited by the hydraulic capacities
- Calculations are based on the machine resting on a uniform and firm surface
- The lifting point is a hypothetical hook placed behind the bucket.

## LIFTING CAPACITY TWO-PIECE BOOM / WITH BLADE UP

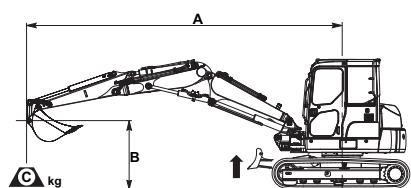

A – Reach from swing centre

B – Bucket hook height

C – Lifting capacities, including bucket (175 kg), bucket linkage and bucket cylinder

– Rating over front

– Rating over side

– Rating at maximum reach

When removing bucket, linkage or cylinder, lifting capacities can be increased by their respective weights.

Arm length	B	A	Additional counterweight			5,0 m		4,0 m		3,0 m	
1.650 mm		4,5 m		730	710	880	850	1.400	1.350	*2.370	2.310
		3,0 m		530	510	840	810	1.270	1.220	2.080	1.990
		1,5 m		460	450	750	720	1.070	1.030	-	-
		0,0 m		480	470	690	670	980	940	*1.570	1.500
		-1,5 m		610	590	700	680	1.000	960	1.640	1.560
1.650 mm		4,5 m	+ 230 kg	820	790	980	950	1.530	1.470	*2.370	*2.370
		3,0 m	+ 230 kg	600	590	940	910	1.400	1.350	2.280	2.170
		1,5 m	+ 230 kg	540	520	850	820	1.200	1.150	-	-
		0,0 m	+ 230 kg	560	540	790	760	1.110	1.070	*1.580	*1.580
		-1,5 m	+ 230 kg	700	680	800	770	1.130	1.080	1.840	1.740
2.000 mm		4,5 m		620	620	910	880	1.430	1.390	*1.790	*1.790
		3,0 m		460	450	850	830	1.300	1.260	2.190	2.090
		1,5 m		410	400	750	730	1.090	1.050	*940	*940
		0,0 m		420	410	680	650	970	930	1.530	1.460
		-1,5 m		520	500	670	650	960	930	1.580	1.500
2.000 mm		4,5 m	+ 230 kg	710	680	1.010	970	1.560	1.510	2.390	*1.790
		3,0 m	+ 230 kg	530	520	950	920	1.440	1.380	2.190	2.280
		1,5 m	+ 230 kg	480	460	850	820	1.220	1.170	*940	*940
		0,0 m	+ 230 kg	490	480	780	750	1.100	1.050	1.730	1.640
		-1,5 m	+ 230 kg	600	580	770	740	1.090	1.050	1.780	1.690

Ratings are based on ISO standard 10567. Rated loads do not exceed 87% of hydraulic lift capacity or 75% of tipping load. Excavators used in object handling operations must comply with the related local regulations and must be equipped with hose burst valves (boom & arm) and an overload warning device in compliance with EN474-5.

- The values marked with an asterisk (\*) are limited by the hydraulic capacities
- Calculations are based on the machine resting on a uniform and firm surface
- The lifting point is a hypothetical hook placed behind the bucket.