

Specifications

ENGINE

The new generation engine has been developed to comply with the strictest emission controls.

Model	Komatsu S4D84E-6BMFD
Type	4-cycle water-cooled diesel engine
Bore × stroke	84 × 90 mm
No. of cylinders	4
Engine power	
at rated engine speed	2.600 rpm
ISO 14396	36,2 kW / 48,5 HP
ISO 9249 (net engine power)	35,2 kW / 47,2 HP
Max. torque/engine speed	156,9 Nm / 1.700 rpm
Aspiration	turbo
Cooling system	water
Air filter type	dry with safety element
Starter motor	electric motor with pre-heating air system for cold climate

OPERATING WEIGHT

Operating weight with standard bucket, fully serviced, +75 kg operator (ISO 6016)	3.080 kg
---	----------

HYDRAULIC SYSTEM

Type	Komatsu CLSS
Hydraulic pump	gear pump
Max. pump flow	62 ltr/min
Max. operating pressure	206 bar
Control valve	3 elements fully servo-controlled SUPER FLOW hydraulic system (option):
Max. pump flow	100 ltr/min
Max. operating pressure	206 bar

TYRES

Standard	10-16.5 8PR
Option	10-16.5 8PR (narrow tread)

CONTROLS

Proportional servo-controls (PPC). The left lever controls the machine movements, the right one controls the working equipment. The pedal controls the auxiliary circuit for attachments. A safety system neutralises all operations when the safety bars are risen or the operator is not seated.

TRANSMISSION

Type	hydrostatic
Pumps	2 × variable displacement with 2 stage
Hydraulic motors	2 × axial pistons
Constant mesh final transmission with “heavy duty” type roller chains, which are immersed in an oil bath.	
No. of travel speeds	2
Max. travel speed	16 km/h
Oil immersed discs for both parking and working breaks with negative action and automatic insertion.	

ELECTRIC SYSTEM

Voltage	12 V
Battery	80 Ah
Alternator	55 A

SERVICE CAPACITIES

Hydraulic system	38 ltr
Fuel tank	68 ltr
Hydraulic transmission (chains)	15,5 + 15,5 ltr
Engine oil	8 ltr

LOADER

Operating capacity (ISO 14397)	900 kg
Tipping load (ISO 14397)	1.800 kg
Standard bucket capacity (ISO 7546)	0,4 m ³
Bucket breakout force (ISO 14397)	1.867 daN (1.950 kg)
Operating capacity with pallet forks	600 kg

ENVIRONMENT

Vibration levels (EN 12096:1997)*	
Hand/arm	≤ 2,5 m/s ² (uncertainty K = 1,2 m/s ²)
Body	≤ 0,5 m/s ² (uncertainty K = 0,2 m/s ²)
* for the purpose of risk assessment under directive 2002/44/EC, please refer to ISO/TR 25398:2006.	

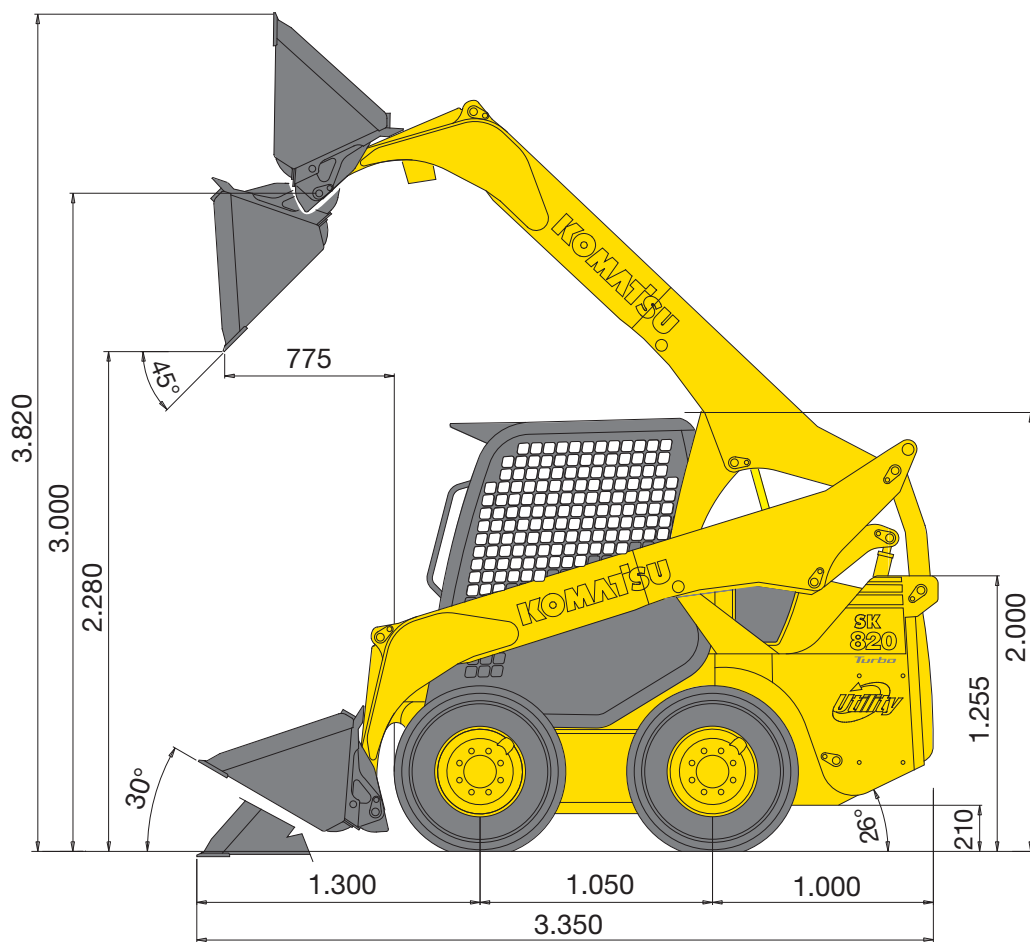
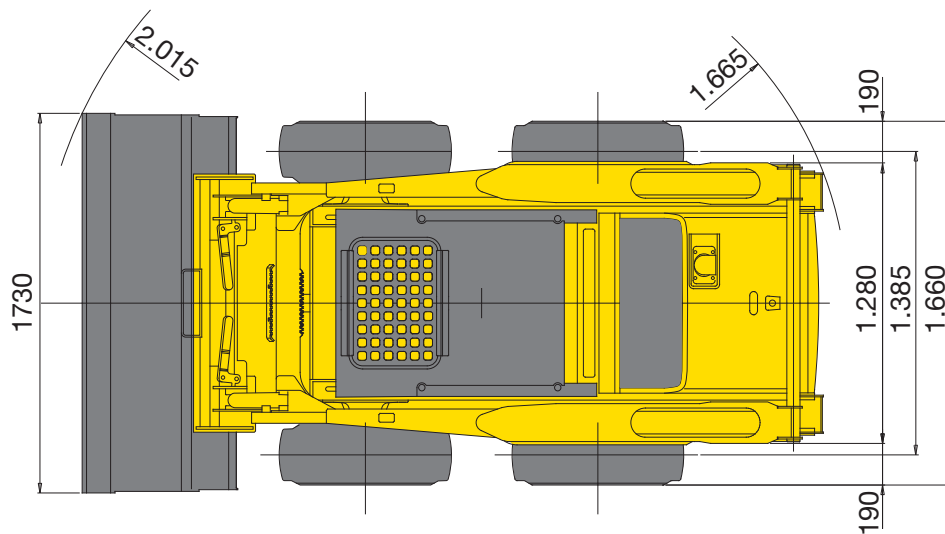

Skid Steer Loader

SK820-5

Standard and Optional Equipment

ENGINE

Komatsu S4D84E-6BMFD turbocharged diesel engine, EU Stage IIIA/EPA Tier III compliant	●
Alternator 55 A	●
Battery 80 Ah	●
Catalytic muffler	○

TRANSMISSION

2 speed transmission	●
----------------------	---

HYDRAULIC SYSTEM

Auxiliary hydraulic circuit for attachments	●
Universal quick-coupler	●
Bucket floating function	●
SUPER FLOW version with 3 elements main valve (with drain line and electric connection)	○
Slow Speed Control (SSC)	○

TYRES AND BRAKES

Standard tyres 10-16.5 8PR	●
Automatic working and parking brakes	●
Narrow tread tyres 10-16.5 8PR	○

SERVICE AND MAINTENANCE

KOMTRAX™ - Komatsu satellite monitoring system	●
Cyclone air pre-filter	○

CABIN

ROPS / FOPS (Class 1) tilting cab	●
Adjustable seat with safety belt	●
Safety bars with incorporated display	●
Instrument panel including:	
- hour meter	
- LCD fuel level indicator	
- LCD engine water temperature indicator	
- safety warning lights: operator onboard, safety bars lowered	●
- other pilot lights: air filter clogging, engine oil pressure, generator, hydraulic oil filter, engine pre-heating, parking brake, working lights, direction indicators, floating	
Accelerator pedal	●
Closed cab with side windows, door (with wiper) and heating or air conditioning	○
Deluxe suspension seat with safety belt	○
Fixed or sliding side windows	○
12 V internal power supply	○

SAFETY EQUIPMENT

Back-up alarm	●
Horn	●
Battery main switch	●
Rotating beacon	○
Accessories for road homologation	○
Rear view mirrors	○
FOPS Class 2 cab	○

LIGHTING SYSTEM

Two front working lights	●
2 rear working lights	○

OTHER EQUIPMENT

Bucket self leveling	●
12 V external power supply	●
Mudguards	○
Additional modular rear counterweight (6 pieces, total 126 kg)	○

ATTACHMENTS

1.730 mm bucket with or without teeth	●
1.550 mm bucket with or without teeth	○
1.800 mm bucket with or without teeth	○
Cutting edge on teeth	○
Bolt-on cutting edge	○
Lifting hooks	○

A wide range of attachments is available. Please consult your distributor for details of the full range.

Other attachments on request

- standard equipment
- optional equipment

Your Komatsu partner:

KOMATSU

**Komatsu Europe
International NV**

Mechelsesteenweg 586
B-1800 VILVOORDE (BELGIUM)
Tel. +32-2-255 24 11
Fax +32-2-252 19 81
www.komatsu.eu

WESS006803 12/2012

Materials and specifications are subject to change without notice.
KOMATSU is a trademark of Komatsu Ltd. Japan.