

ENGINE

Model	Komatsu SAA6D107E-2 Common rail direct injection, water-cooled, emissionised, turbocharged, after-cooled diesel
Engine power at rated engine speed	2.000 rpm
ISO 14396	115 kW / 153 HP
ISO 9249 (net engine power)	111 kW / 149 HP
No. of cylinders	6
Bore x stroke	107 x 124 mm
Displacement	6,69 ltr
Lubricating system	Gear pump, pressure feed lubrication
Filter	Main-flow filter
Electrical system	24 V
Battery	2 x 110 Ah
Alternator	60 A
Air-filter type	Dry-air filter with automatic dust emission and preliminary purification including a dust display

TRANSMISSION

Drive system	Electronically controlled hydrostatic transmission, switchable in all directions under full power. Fixed ratio gearbox. Variable speed limiter
Hydrostatic pump	1 variable piston pump
Hydrostatic motor	2 variable piston motors
Speed ranges (forwards/backwards)	4/4
Max. travel speeds (forwards/backwards) (Tyres 20.5 R25)	
1. speed range	1-13 km/h
2. speed range	13 km/h
3. speed range	19 km/h
4. speed range	38 km/h

CHASSIS AND TYRES

System	4-wheel drive
Front axle	HD axle, semi-floating, fixed type, TPD-differential, (LSD-differential optional)
Rear axle	HD axle, semi-floating, centre-pin support, 20° swing angle, TPD-differential, (LSD-differential optional)
Reduction gear	Spiral bevel gear
Differential	Straight bevel gear pair
Final drive	Planetary gear in an oil bath
Tyres	20.5 R25 (standard)

SERVICE REFILL CAPACITIES

Cooling system	28 ltr
Fuel tank	186 ltr
Engine oil	23 ltr
Hydraulic system	78 ltr
Axle front	18,5 ltr
Axle rear	18 ltr
Transfer	7,0 ltr

BRAKES

Operating brakes	Completely hydraulic dual-circuit system, running in oil bath, multi-disc brakes on all wheels, service-free
Parking brake	Operated mechanically, running in oil bath, multi-disc brake, service-free
Emergency brake	Uses the parking brake

HYDRAULIC SYSTEM

Type	Komatsu CLSS (Closed Centre Load Sensing System)
Hydraulic pump	Piston pump
Working pressure (max)	310 kgf/cm ²
Circulating capacity of the hydraulic pump	150 ltr/min
No. of boom/bucket cylinders	2/1
Type	Double-action
Bore diameter x stroke	
Boom cylinder	110 x 717 mm
Bucket cylinder	140 x 480 mm
Hydraulic control lever	Servo-controlled, single lever
Hydraulic cycle with rated load bucket filling	
Raise time	5,7 s
Lowering time (empty)	3,2 s
Dumping time	2,0 s

STEERING SYSTEM

System	Articulated frame steering
Type	Completely hydraulic power steering
Steering angle to either side	40°
Hydraulic pump	Piston pump
Working pressure	210 kgf/cm ²
Pumping capacity	150 ltr/min
No. of steering cylinders	2
Type	Double-action
Bore diameter x stroke	70 x 453 mm
Smallest turn (outer edge of the tyre 20.5 R25)	5.240 mm

CABIN

Two-door SpaceCab™ in conformity with ISO 3471 with ROPS (roll over protective structure) in conformity with SAE J1040c and FOPS (falling object protective structure) in conformity with ISO 3449. The air-conditioned pressurised cabin is mounted upon hydrobearings and is noise dampened.

ENVIRONMENT

Engine emissions	Fully complies with EU Stage IIIB and EPA Tier 4 interim exhaust emission regulations
Noise levels	
LwA external	105 dB(A) (2000/14/EC Stage II)
LpA operator ear	69 dB(A) (ISO 6396 dynamic test)
Vibration levels (EN 12096:1997)*	
Hand/arm	≤ 2,5 m/s ² (uncertainty K = 0,20 m/s ²)
Body	≤ 0,5 m/s ² (uncertainty K = 0,11 m/s ²)

* for the purpose of risk assessment under directive 2002/44/EC, please refer to ISO/TR 25398:2006.

Dimensions & Performance Figures

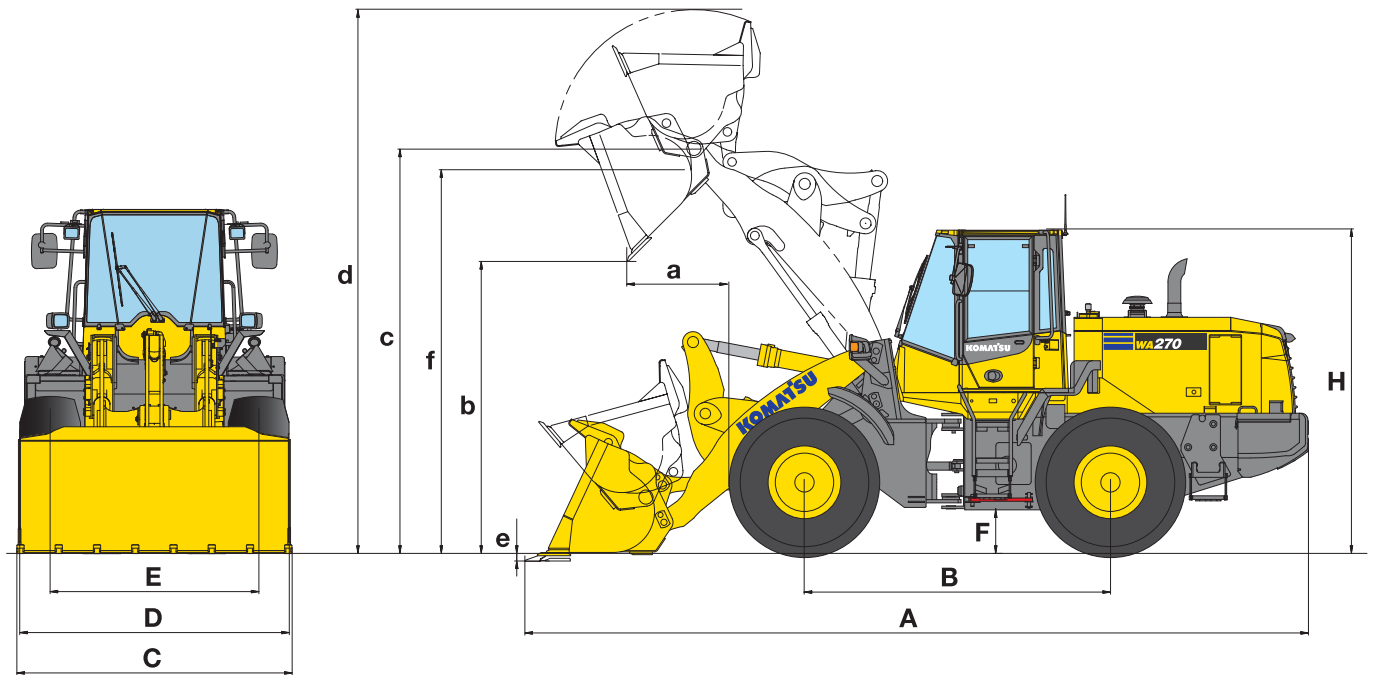

MEASUREMENTS AND WORKING SPECIFICATIONS

		Earthmoving		Stockpile		Universal	
		w. teeth	w. BOC	w. teeth	w. BOC	w. teeth	w. BOC
Bucket mount (direct/quick-coupler)		direct	direct	direct	direct	direct	direct
Bucket capacity (heaped, ISO 7546)	m³	2,1	2,3	2,3	2,5	2,1	2,2
Sales code	3997	C32	C33	C22	C23	C02	C03
Material density (max.)	t/m ³	1,95	1,75	1,75	1,6	1,95	1,85
Bucket weight	kg	1.100	1.110	1.125	1.135	985	995
Static tipping load, straight	kg	10.190	10.140	10.110	10.045	10.330	10.250
Static tipping load, 40° articulated	kg	8.900	8.855	8.830	8.770	9.045	8.970
Break-out force hydraulic	kN	138	130,6	133,3	126,4	138,7	131,3
Lifting capability hydr. at ground level	kN	118,2	118,3	118,3	118,5	119,6	120
Operating weight	kg	12.705	12.715	12.730	12.740	12.590	12.600
Turning radius at corner of tyres	mm	5.240	5.240	5.240	5.240	5.240	5.240
Turning radius at bucket edge	mm	5.845	5.800	5.850	5.805	5.845	5.800
a Reach at 45°	mm	1.070	935	1.095	960	1.065	930
b Dump height at 45°	mm	2.840	2.955	2.815	2.935	2.840	2.960
c Hinge pin height	mm	3.965	3.965	3.965	3.965	3.965	3.965
d Height top edge of bucket	mm	5.290	5.290	5.290	5.290	5.230	5.230
e Digging depth	mm	125	150	125	150	125	150
f Max. loading height at 45°	mm	3.680	3.680	3.680	3.680	3.680	3.680
A Overall length, bucket grounded	mm	7.380	7.230	7.415	7.265	7.375	7.225
B Wheelbase	mm	2.900	2.900	2.900	2.900	2.900	2.900
C Bucket width	mm	2.550	2.540	2.550	2.540	2.550	2.540
D Width over tyres	mm	2.470	2.470	2.470	2.470	2.470	2.470
E Track width	mm	1.930	1.930	1.930	1.930	1.930	1.930
F Ground clearance	mm	465	465	465	465	465	465
H Overall height	mm	3.200	3.200	3.200	3.200	3.200	3.200

All measurements with tyres 20.5 R25 & with add. counterweight.
BOC: bolt-on cutting edge



CHANGE IN DATA CAUSED BY:

		Tyres 20.5 R25 L2	Tyres 20.5 R25 L5
Operating weight	kg	-330	+680
Static tipping load, straight	kg	-230	+450
Static tipping load, 40° articulated	kg	-200	+400
Reach at 45°	mm	+70	-20
Dump height at 45°	mm	-75	+25
Width over tyres	mm	-75	+0
Overall height	mm	-75	+25

Earthmoving		Stockpile		Universal	
w. teeth	w. BOC	w. teeth	w. BOC	w. teeth	w. BOC
QC	QC	QC	QC	QC	QC
2,1	2,3	2,3	2,5	2,0	2,1
C62	C63	C66	C67	C42	C43
1,8	1,6	1,6	1,5	1,9	1,8
1.080	1.090	1.105	1.115	950	960
9.355	9.320	9.320	9.265	9.495	9.470
8.130	8.095	8.095	8.045	8.270	8.245
113,4	108,4	110,2	105,5	113,9	108,8
117,8	118	117,5	117,8	119,3	119,8
13.070	13.080	13.095	13.105	12.940	12.950
5.240	5.240	5.240	5.240	5.240	5.240
5.905	5.855	5.915	5.865	5.905	5.855
1.225	1.095	1.250	1.120	1.225	1.090
2.690	2.815	2.665	2.790	2.695	2.815
3.965	3.965	3.965	3.965	3.965	3.965
5.450	5.450	5.450	5.450	5.390	5.390
115	140	115	140	115	140
3.680	3.680	3.680	3.680	3.680	3.680
7.585	7.440	7.620	7.620	7.580	7.435
2.900	2.900	2.900	2.900	2.900	2.900
2.550	2.540	2.550	2.540	2.550	2.540
2.470	2.470	2.470	2.470	2.470	2.470
1.930	1.930	1.930	1.930	1.930	1.930
465	465	465	465	465	465
3.200	3.200	3.200	3.200	3.200	3.200

TYPICAL MATERIAL DENSITY – LOOSE (IN kg/m³)

Basalt	1.960
Bauxite, Kaolin	1.420
Earth, dry, ex store	1.510
Earth, wet, excavated	1.600
Gypsum, broken	1.810
Gypsum, crushed	1.600
Granite, broken	1.660
Limestone, broken	1.540
Limestone, crushed	1.540
Gravel, unscreened	1.930
Gravel, dry	1.510
Gravel, dry, 6-50 mm	1.690
Gravel, wet, 6-50 mm	2.020
Sand, dry, loose	1.420
Sand, damp	1.690
Sand, wet	1.840
Sand and clay, loose	1.600
Sand and gravel, dry	1.720
Sandstone	1.510
Slate	1.250
Slag, broken	1.750
Stone, crushed	1.600
Clay, natural	1.660
Clay, dry	1.480
Clay, wet	1.660
Clay and gravel, dry	1.420
Clay and gravel, wet	1.540

Dimensions & Performance Figures

FORK TINES

Sales code		C57
Fork tine length	mm	1.200
A Max. reach at ground level	mm	965
B Max. reach	mm	1.630
C Max. reach at max. stacking height	mm	725
a Max. height fork-carrier	mm	4.765
b Hinge pin height	mm	3.965
c Max. stacking height	mm	3.820
d Height of forks at maximum reach	mm	1.820
Max. tipping load, straight	kg	7.275
Max. tipping load, articulated	kg	6.365
Max. payload as per EN 474-3, 80%	kg	5.090
Max. payload as per EN 474-3, 60%	kg	3.815
Weight in working order with fork tines	kg	12.555

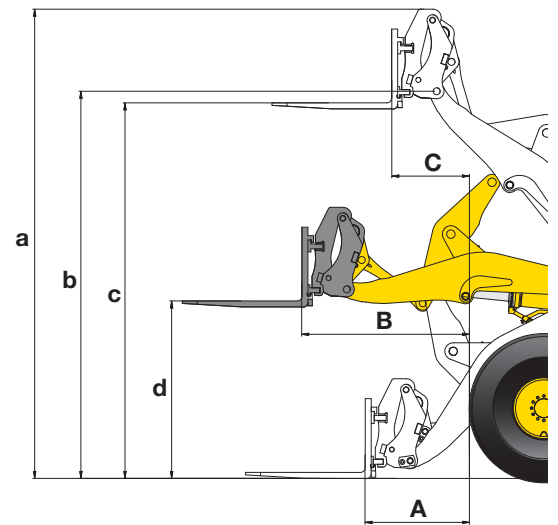

LIGHT MATERIAL BUCKET

	w. BOC	
	Q36	Q67
Sales code	Q36	Q67
Bucket mount (direct/quick-coupler)	QC	QC
Bucket capacity (heaped, ISO 7546)	m ³ 3,5	3,5
Material density	t/m ³ 1,0	1,0
Rated load	kg 3.500	3.500
Bucket width	mm 2.550	2.740
Bucket weight	kg 1.300	1.020
A Reach at 45°	mm 1.255	1.295
a Height top edge of bucket	mm 5.465	5.555
b Hinge pin height	mm 3.905	3.965
c Max. loading height at 45°	mm 3.620	3.620
d Dump height at 45°	mm 2.570	2.570

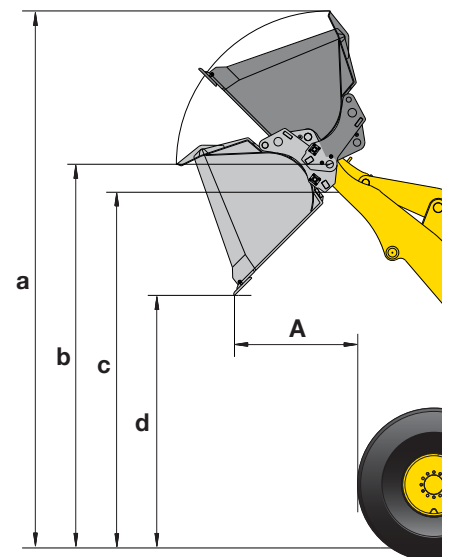

All measurements with tyres 20.5 R25 & with add. counterweight.



HIGH-DUMP BUCKET

		w. BOC
Sales code		Q41
Bucket mount (direct/quick-coupler)		QC
Bucket capacity (heaped, ISO 7546)	m ³	3,1
Material density	t/m ³	1,0
Rated load	kg	3.100
Bucket width	mm	2.740
Bucket weight	kg	1.975
A Reach at 45°	mm	1.660
a Height top edge of bucket	mm	6.300
b Hinge pin height	mm	5.025
c Max. loading height at 45°	mm	4.810
d Dump height at 45°	mm	4.660

Type B, dump cylinders located outside bucket

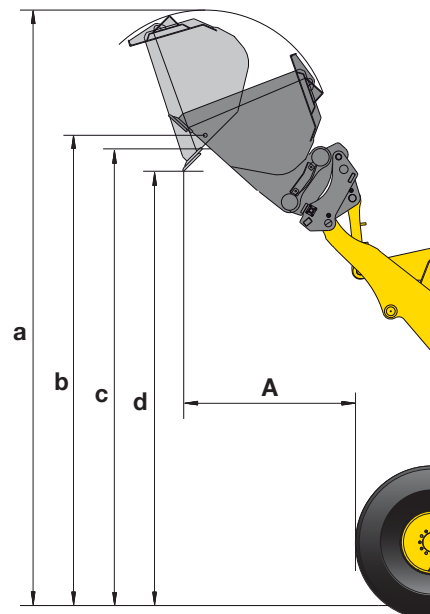

HIGH-DUMP BUCKET (WASTE HANDLING)

		w. BOC
Sales code		Q86
Bucket mount (direct/quick-coupler)		QC
Bucket capacity (heaped, ISO 7546)	m ³	2,5
Material density	t/m ³	1,0
Rated load	kg	2.500
Bucket width	mm	2.550
Bucket weight	kg	2.580
A Reach at 45°	mm	1.515
a Height top edge of bucket	mm	5.965
b Hinge pin height	mm	4.665
c Max. loading height at 45°	mm	4.510
d Dump height at 45°	mm	4.290

Type B, dump cylinders located outside bucket

