

Specifications

ENGINE

Model	Komatsu S4D95LWE-5
Engine power	
at rated engine speed	2.270 rpm
ISO 14396	50,0 kW/67,1 HP
Max. torque/engine speed	240 Nm/1.600 rpm
No. of cylinders	4
Bore × stroke	95 × 115 mm
Displacement	3,3 ltr
Injection system	Direct injection
Electrical system	12 V
Battery	92 Ah
Alternator	90 A
Air filter type	Dry air filter with pre-filter and safety cartridge

TRANSMISSION

Drive system	Hydrostatic transmission, switchable in all directions under full power
Hydrostatic pump	1 variable piston pump
Hydrostatic motor	1 variable piston motor
Speed ranges (forwards/backwards)	2/2
Travel speeds (forwards/backwards) 20 km/h version	
1. speed range	0 - 4,5 km/h
2. speed range	0 - 20 km/h
Travel speeds (forwards/backwards) 30 km/h version	
1. speed range	0 - 8,5 km/h
2. speed range	0 - 30 km/h

CHASSIS AND TYRES

Type	Low build rear axle oscillation for optimum stability and for best performance in earthmoving applications
System	4-wheel drive
Axles	Planetary rigid axles with automatic limited slip differentials in both axles 100% locking differentials as option
Oscillation	Rear axle oscillation for optimum stability, oscillation angle 10°
Tyres	405/70 R18 (standard)

SERVICE REFILL CAPACITIES

Cooling system	9,1 ltr
Fuel tank	140 ltr
Engine oil	11,5 ltr
Hydraulic system	53 ltr
Front axle	9,4 ltr
Rear axle	9,4 ltr
Transfer box	1,3 ltr

BRAKES

Operating brakes	Combined inch brake pedal actuates maintenance free wet-disc type brakes in the front axle. Self-braking via the hydrostatic drive.
Parking brake	Dry disc

HYDRAULIC SYSTEM

System	Open hydraulic system
Working pressure	270 bar
Circulating capacity of the hydraulic pump	64 ltr/min
No. of boom/bucket cylinders	2/1
Type	Double-action
Bore diameter × stroke	
Boom cylinder	70 × 658 mm
Bucket cylinder	90 × 450 mm
Hydraulic control lever	Multifunction lever
Kinematic	Z-Kinematic with highest breakout force. Parallel movement when using dedicated fork tines.
Hydraulic cycle with rated load bucket filling	
Raise time	4,9 s
Lowering time (empty)	2,8 s
Dumping time	1,0 s

STEERING SYSTEM

System	Articulated frame steering
Type	Hydrostatic
Steering angle to either side	42°
Steering pump	Gear pump
Working pressure	185 bar
No. of steering cylinders	1
Type	Double-action
Bore diameter × stroke	70 × 378 mm
Smallest turn (outer edge of the tyre 405/70 R18)	3.985 mm

CABIN

Cabin in conformity with ISO 3471 with ROPS (roll over protective structure) in conformity with SAE J1040c and FOPS (falling object protective structure) in conformity with ISO 3449. The pressurised cabin is mounted upon hydrobearings and is noise dampened. Tilttable for best servicing access.

ENVIRONMENT

Engine emissions	Fully complies with EU Stage IIIA and EPA Tier III exhaust emission regulations
Noise levels	Noise levels (external/internal) fully comply 2000/14/EC Stage II and 98/37/EC
Vibration levels (EN 12096:1997)*	
Hand/arm	≤ 2,5 m/s ² (uncertainty K = 0,73 m/s ²)
Body	≤ 0,5 m/s ² (uncertainty K = 0,46 m/s ²)

* for the purpose of risk assessment under directive 2002/44/EC, please refer to ISO/TR 25398:2006.

Dimensions & Performance Figures

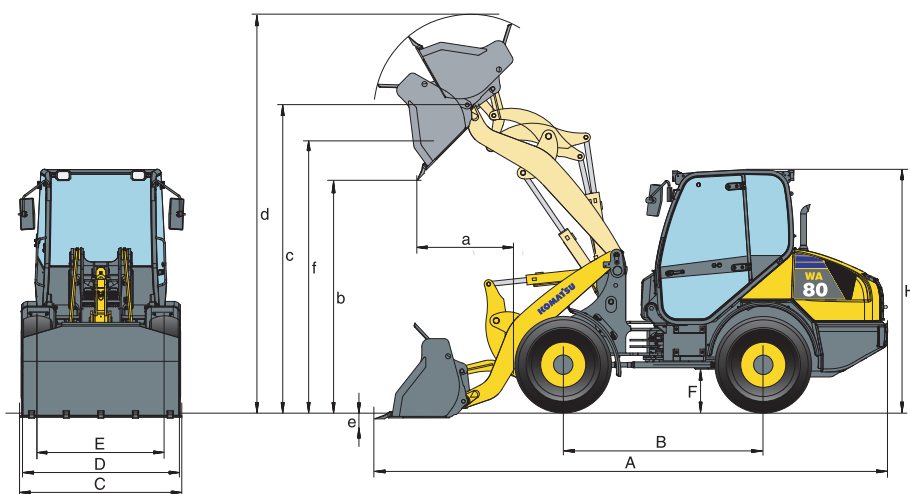

MEASUREMENTS AND WORKING SPECIFICATIONS

		Universal		Light materials	4-in-1
		w. teeth	w/o teeth	w/o teeth	w. teeth
Bucket capacity (heaped, ISO 7546)	m³	1,0	1,0	1,25	0,8
Sales code		C61	C11	C14	C16
Material density	t/m ³	1,8	1,8	1,25	1,8
Bucket weight without teeth	kg	422	400	340	615
Static tipping load, straight	kg	4.310	4.340	4.295	4.035
Static tipping load, 40° articulated	kg	3.720	3.750	3.710	3.445
Breakout force hydraulic	kN	56,7	56,7	41,8	48,5
Lifting capability hydr. at ground level	kN	50,3	50,3	53,2	53,5
Operating weight	kg	5.545	5.525	5.560	5.835
Turning radius at corner of tyres	mm	3.985	3.985	3.985	3.985
Turning radius at bucket edge	mm	4.420	4.420	4.550	4.490
a Reach at 45°	mm	995	995	1.035	985
b Dump height at 45°	mm	2.425	2.425	2.330	2.425
c Hinge pin height	mm	3.210	3.210	3.210	3.210
d Height top edge of bucket	mm	4.170	4.170	4.250	4.100
e Digging depth	mm	90	90	135	100
f Max. loading height at 45°	mm	2.910	2.910	2.895	2.900
A Overall length, bucket grounded	mm	5.630	5.495	5.720	5.710
B Wheelbase	mm	2.260	2.260	2.260	2.260
C Bucket width	mm	1.915	1.915	1.870	1.900
D Width over tyres	mm	1.875	1.875	1.875	1.875
E Track width	mm	1.470	1.470	1.470	1.470
F Ground clearance	mm	300	300	300	300
H Overall height	mm	2.665	2.665	2.665	2.665

All measurements with tyres 405/70 R18

PERFORMANCE FIGURES WITH FORK TINES

		C24	C23
Sales code		C24	C23
Fork tine type		FEM IIA	FEM IIB
Fork tine length	mm	1.200	1.200
g Max. reach at ground level	mm	890	950
h Max. reach	mm	1.380	1.380
j Max. reach at max. stacking height	mm	680	680
k Max. height fork-carrier	mm	3.660	3.660
l Hinge pin height	mm	3.210	3.210
m Max. stacking height	mm	3.080	2.955
n Height of forks at maximum reach	mm	1.490	1.365
Max. tipping load, straight	kg	3.235	3.230
Max. tipping load, articulated	kg	2.770	2.765
Max. payload as per EN 474-3, 80%	kg	2.210	2.210
Max. payload as per EN 474-3, 60%	kg	1.660	1.650
Weight in working order with fork tines	kg	5.435	5.440

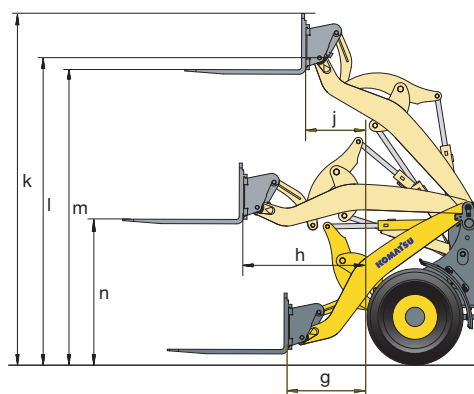

Wheel Loader

WA80-6

Standard and Optional Equipment

ENGINE

Komatsu S4D95LWE-5 ecot3 diesel engine, EU Stage IIIA compliant	●
Alternator 90 A/12 V	●
Starter motor 2,2 kW/12 V	●
Battery 92 Ah/12 V	●

TRANSMISSION AND BRAKES

Combined inch/brake pedal	●
Creeping function	○

CHASSIS AND TYRES

Heavy-duty axles	●
LSD-differential front and rear	●
100% manual locking differentials front and rear	○
Various tyre types and sizes on request	○

HYDRAULIC SYSTEM

3-spool main control valve	●
Multifunction lever	●
Hydraulic quick-coupler	●
Electrical actuation of 3rd hydraulic circuit	●
Loader control with return-to-dig	○
Auto-inch valve	○
Biodegradable oil for hydraulic system	○

SERVICE AND MAINTENANCE

KOMTRAX™ - Komatsu satellite monitoring system	●
Tool-set	●
Air cleaner system with cyclone pre-cleaner	○
Wide core radiator, radiator fan with reversing function	○
Automatic central lubrication	○

CABIN

Spacious driver's cab with heating	●
Tilting cab	●
ROPS/FOPS frame according to SAE	●
All-round tinted glazing	●
Front laminated glass	●
Heated rear window	●
Rear window wiper	●
Sun visor	●
Adjustable steering column	●
Suspended seat	●
Seat belt (EU standard)	●
Adjustable wrist rest with integrated small storage box	●
Large storage box at left hand side	●
Instrument panel with gauges for speed, coolant temperature, fuel level, air filter warning light etc.	●
12 Volt power supply	●
Adjustable high comfort seat	○
Air conditioning	○
Radio	○
Sun reflection decal for cab/canopy roof	○

SAFETY EQUIPMENT

Emergency steering system	●
Back-up alarm	●
Horn	●
Beacon light	○
Immobilizer	○
Immobilizer with master key	○
Anti-drop valve	○
Battery main switch	○
Fire extinguisher	○

LIGHTING SYSTEM

Halogen headlights	●
Reversing lights	●
Additional lights front and rear	○
Xenon headlights, halogen rear lights	○

OTHER EQUIPMENT

Z-bar boom (parallel movement when using dedicated fork tines)	●
Counterweight	●
Electronically controlled suspension system load stabilizer (ECSS)	○
Special custom colour	○
Bucket level indicator	○

ATTACHMENTS

Bucket with or without teeth	○
4-in-1 bucket	○
Light material buckets	○
Fork carrier and tines	○
Cutting edge guard	○

Further work equipment, accessories and special application arrangements on request

All buckets and attachments quick-coupler mounted

Other attachments on request

- standard equipment
- optional equipment

Your Komatsu partner:

KOMATSU

**Komatsu Europe
International NV**

Mechelsesteenweg 586
B-1800 VILVOORDE (BELGIUM)
Tel. +32-2-255 24 11
Fax +32-2-252 19 81
www.komatsu.eu

VESS002303 11/2010

Materials and specifications are subject to change without notice.
KOMATSU is a trademark of Komatsu Ltd. Japan.