

Specifications

ENGINE

The engine has been developed in compliance with the strictest European standards (97/68EC 2004/26/EC – EU Stage IIIA) on the reduction of exhaust emissions.

Model	Komatsu SAA4D104E-1
Type	vertical, 4-cycle water-cooled diesel engine
Displacement.....	4.485 cm ³
Bore × stroke.....	104 × 132 mm
No. of cylinders	4
Compression ratio.....	17,5:1
Combustion.....	direct injection (DI)
Aspiration	turbo-intercooled
Engine power	
at rated engine speed.....	2.200 rpm
ISO 14396.....	74 kW / 99,2 HP
Max. torque/engine speed	420 Nm/1.200 rpm
Cooling system.....	radiator
Air filter type	dry filter with safety element
Starting system	electric motor with pre-heating air system for cold climate

OPERATING WEIGHT

Standard machine operating weight	8.160 kg
Total machine weight.....	9.000 kg
Operating weight increase	
standard bucket.....	-300 kg
offset boom.....	+190 kg
standard arm.....	-230 kg
pallet forks	-280 kg
forks for 4×1 bucket	+150 kg

HYDRAULIC SYSTEM

SyncroSystem hydraulics allows the operator very precise and simultaneous movements. This system incorporates two different working modes: Power and Economy. The advanced hydraulic system includes also the function “Speed Up” to increase the working speed of the front loader.

System	SyncroSystem
Type	Closed Load Sensing System, CLSS
Pumps type	variable displacement axial pistons
Pumps control system.....	Load Sensing
Main valve	LIFD “Load Independent Flow Divider” modular type
Max delivery	165 ltr/min
Working pressure.....	250 bar

ELECTRIC SYSTEM

The electric system is easily accessible and protected: connections are sealed and waterproof, and comply with the strictest international safety rules.

Voltage.....	12 V
Battery	155 Ah
Alternator.....	120 A
Starter.....	3 kW

ENVIRONMENT

Vibration levels (EN 12096:1997)*

Hand/arm	≤ 2,5 m/s ² (uncertainty K = 1,2 m/s ²)
Body	≤ 0,5 m/s ² (uncertainty K = 0,2 m/s ²)

* for the purpose of risk assessment under directive 2002/44/EC, please refer to ISO/TR 25398:2006.

STEERING SYSTEM

The front steering wheels are controlled by a hydrostatic “Load Sensing” with steering priority valve system.

Turning radius (without using brakes):	
at the corner of the bucket	4.350 mm
at outer edge of front tyre	4.000 mm
Turning radius (using brakes):	
at the corner of the bucket	4.700 mm
at outer edge of front tyre	3.200 mm

TRANSMISSION

Electronically-controlled, four-wheel drive, “Full Power Shift” transmission. The control is automatic, with a knob used to select the direction of travel and the gears, at full power, without losing traction.

TRAVELLING SPEEDS

GEAR	FORWARD	REVERSE
1st	6,5 km/h	6,5 km/h
2nd	11 km/h	11 km/h
3rd	23 km/h	23 km/h
4th	40 km/h	40 km/h

AXLES

“Heavy duty” axles with planetary reduction gears in the wheel hubs. Front axle total oscillation angle 20°. Differential total lock in the rear axle controlled by a switch on the loader’s lever.

Max. front strength (Dynamic).....	8.500 daN
Max. rear strength (Dynamic)	7.600 daN

BRAKES

Oil immersed disc brakes are actuated by individual braking on each rear wheel with 2 separate pedals. Total integral braking on the 4 wheels is activated by operating the two pedals at the same time.

Disc diameter	300 mm
The calliper parking or safety brake is operated through a hand lever.	

TYRES

Standard:

front	12.5/80 R18 - 10 PR
rear	16.9 × 28 - 12 PR

Option:

front	365/70 R18; 320/80 R18 IT 530; 12.5 - 20 MPT 10 PR
rear	18.4 × 26 - 12 PR; 440/80 R28 IT 530; 16.9 - 30 IND 10 PR

CABIN

ROPS (ISO 3471, SAEJ1040) and FOPS (ISO 3449, SAEJ 231) cab designed in order to offer the best visibility, ergonomics, low noise and comfort. Two doors, full opening rear window with front and rear windscreen wipers. Internal lay out includes full adjustable seat, fresh filtered air intake ventilation and easy to read front and side dash board.

FRAME

The frame is a reinforced and closed box structure, which increases stiffness and reliability.

LOADER

The design of the front loader allows excellent parallelism when lifting and lowering the bucket. Furthermore, thanks to the linkage geometry, the greasing points have been reduced.

Standard bucket width	2.320 mm
Standard bucket capacity (ISO 7546)	1,03 m ³
STD bucket weight	430 kg
Lifting capacity	
at maximum height	3.820 daN (3.900 kg)
Lifting capacity	
at ground level (ISO 14397)	5.195 daN (5.300 kg)
Breakout force (ISO 14397)	6.383 daN (6.500 kg)
4x1 bucket width	2.340 mm
4x1 bucket capacity (ISO 7546)	1,0 m ³

DIMENSIONS

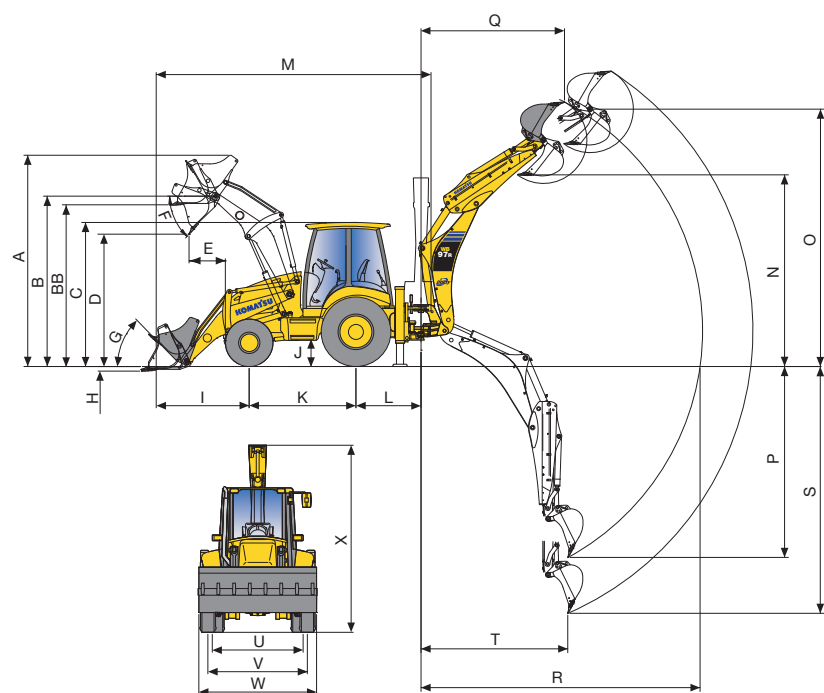

A	max height	4.298 mm
B	pin height	3.428 mm
BB	forks loading max height	3.182 mm
C	cab height	2.900 mm
D	max dumping height	2.778 mm
E	max dumping reach (45°)	724 mm
F	dumping angle	43°
G	rollback angle	45°
H	digging depth	137 mm
I	bucket reach (in transport)	2.133 mm
J	ground clearance	380 mm
K	wheel base	2.173 mm
L	backhoe swing centre distance	1.325 mm
M	transport length	5.933 mm
N	dumping height SAE	3.895 mm
	max dumping height	4.386 mm
	- with extended telescopic SAE	4.796 mm
	- with extended telescopic max	5.152 mm

REFILLS

Engine oil	12,8 ltr
Cooling system	16,5 ltr
Fuel tank	150 ltr
Hydraulic oil tank	41 ltr
Hydraulic oil system capacity	97 ltr
Front axle oil	8,5 ltr
Rear axle oil	14,5 ltr
Gearbox oil	16 ltr

BACKHOE

The boom has a reinforced structure and allows 180° rotation, still preserving high torque. The casted swing support and arm ends ensure high fatigue resistance. Vertical outriggers with adjustable wear device.

Bucket breakout force (ISO 6015)	5.980 daN (6.100 kg)
Arm breakout force (ISO 6015)	3.920 daN (4.000 kg)

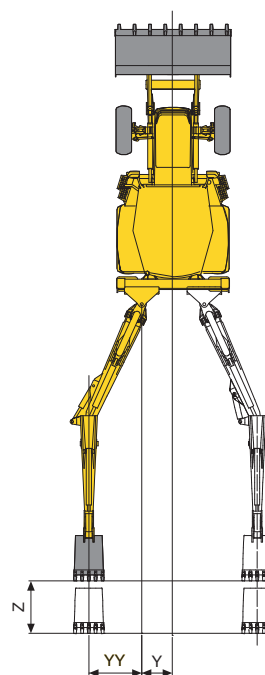

O	max digging height	6.011 mm
	- with extended telescopic	6.789 mm
P	digging depth SAE	4.557 mm
	- with extended telescopic	5.806 mm
Q	reach at max height	2.760 mm
	- with extended telescopic	4.176 mm
R	max reach from swing centre	6.039 mm
	- with extended telescopic	7.175 mm
S	max digging depth	5.270 mm
	- with telescopic	6.430 mm
T	digging reach	1.973 mm
U	rear tread	1.800 mm
V	front tread	1.910 mm
W	overall width (with bucket)	2.320 mm
X	transport hoe height	3.750 mm
	- with telescopic	3.860 mm
Y	side shift	605 mm
YY	side shift with offset	1.080 mm
Z	telescopic stroke	1.240 mm

When used in object handling operations, the backhoe portion must be equipped with hose burst valves (boom, arm and overload warning device) in compliance with EN474-4 and must operate in accordance with the related local regulations.