

KOMATSU

D61EX-24 **D61PX-24**

EU Stage IV Engine

CRAWLER DOZER

D61



ENGINE POWER

126 kW / 169 HP @ 2.200 rpm

OPERATING WEIGHT

D61EX-24: 18.520 kg
D61PX-24: 19.460 kg

BLADE CAPACITY

D61EX-24: 3,4 m³
D61PX-24: 3,8 m³

Walk-Around

D61EX / PX-24



ENGINE POWER

126 kW / 169 HP @ 2.200 rpm

OPERATING WEIGHT

D61EX-24: 18.520 kg
D61PX-24: 19.460 kg

BLADE CAPACITY

D61EX-24: 3,4 m³
D61PX-24: 3,8 m³



INCREASED PRODUCTIVITY & OUTSTANDING FUEL ECONOMY

Powerful and Environmentally Friendly

- EU Stage IV engine
- Highly efficient hydrostatic drive line (HST)
- Adjustable idle shutdown

Optimised Work Equipment

- Straight Power Angle Tilt blade with adjustable pitch
- Multishank parallelogram ripper (EX)

First-Class Operator Comfort

- Unique super-slant nose design
- Quiet and comfortable cab
- Fully adjustable air-suspended seat

State-of-the-Art Controls

- Palm Command Control System joysticks (PCCS)
- HST with automatic speed changes
- Large TFT colour multi-monitor

Tough and Reliable

- Low-drive "PLUS" undercarriage
- Sturdy, rugged design
- Self-adjusting idler support
- Rear-mount radiator with swing-up hydraulic fan

KOMTRAX™

- Komatsu Wireless Monitoring System
- 3G mobile communications
- Integrated communication antenna
- Increased operational data and fuel savings



Complimentary maintenance program for customers

Powerful and Environmentally Friendly

D61EX/PX-24



Highly efficient hydrostatic drive line

The hydrostatic drive line is a key factor in the performance of the D61-24 dozer. It supplies high drawbar pull when needed and a highly fuel efficient drive line for grading and precision work. With a choice between two operating modes, the operator can select either “quick-shift” or “variable speed” to match a complete range of applications in the most economic and easy way.

Hydrostatic transmission (HST) control system

The unique, Komatsu-designed hydrostatic transmission controller monitors the engine output and working equipment or travel load. It controls the HST pumps and motors displacement to deliver optimum speed and drawbar pull. In addition, the controller provides ample power to both tracks when turning, enabling counter rotation at very low speeds and making the D61-24 extremely manoeuvrable.

Efficient hydrostatic engine cooling fan

The cooling fan always runs at the lowest convenient speed. Rotation and velocity are electronically adjusted based on the temperature of the engine coolant and hydraulic oil. This reduces fuel consumption and operating noise levels, and requires less horsepower than a belt-driven fan. For extra efficiency, the fan also has a large air outlet surface.

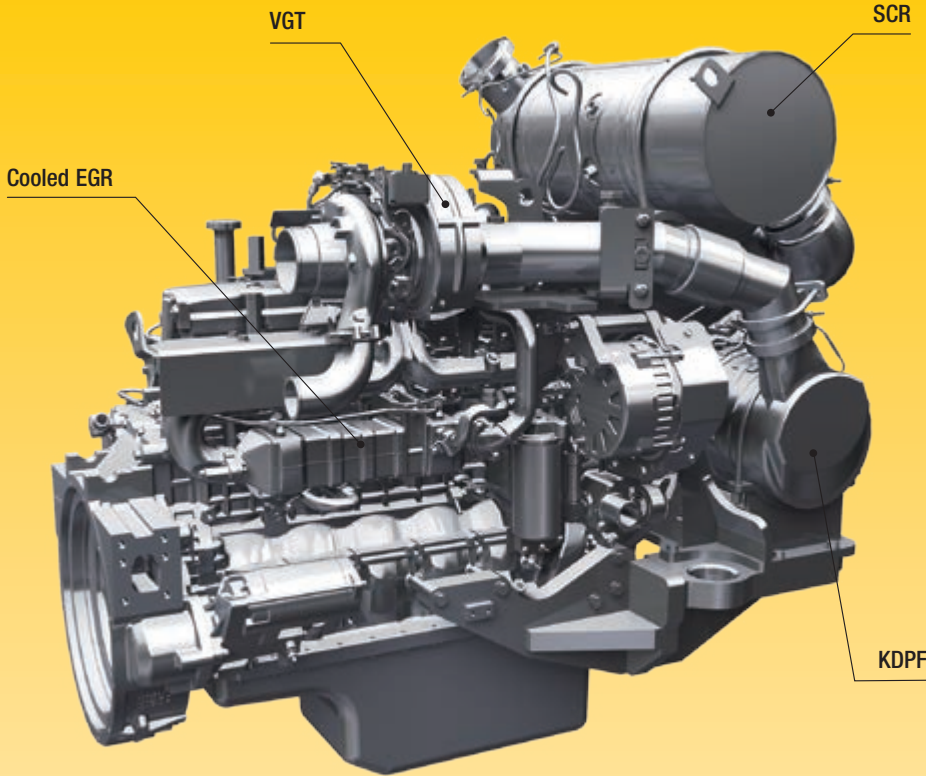

Komatsu EU Stage IV

The Komatsu EU Stage IV engine is productive, dependable and efficient. With ultra-low emissions, it provides a lesser environmental impact and a superior performance to help reduce operating costs and lets the operator work in complete peace of mind.

Heavy-duty aftertreatment

The aftertreatment system combines a Komatsu Diesel Particulate Filter (KDPF) and Selective Catalytic Reduction (SCR). The SCR system injects the correct amount of AdBlue® at the proper rate to break down NOx into water (H₂O) and nontoxic nitrogen gas (N₂). NOx emissions are reduced by 80% vs. EU Stage IIIB engines.

Exhaust Gas Recirculation (EGR)

Cooled EGR is a technology well-proven in current Komatsu engines. The increased capacity of the EGR cooler now ensures very low NOx emissions and a better engine performance.

Komatsu Closed Crankcase Ventilation (KCCV)

Crankcase emissions (blow-by gas) are passed through a CCV filter. The oil mist trapped in the filter is returned back to the crankcase while the filtered gas is returned to the air intake.

High-Pressure Common Rail (HPCR)

To achieve complete fuel burn and lower exhaust emissions, the heavy-duty High-Pressure Common Rail fuel injection system is computer controlled to deliver a precise quantity of pressurised fuel into the redesigned engine combustion chamber by multiple injections.

Variable Geometry Turbo (VGT)

The VGT provides optimal airflow to the engine combustion chamber under all speed and load conditions. Exhaust gas is cleaner, fuel economy is improved while machine power and performance are maintained.

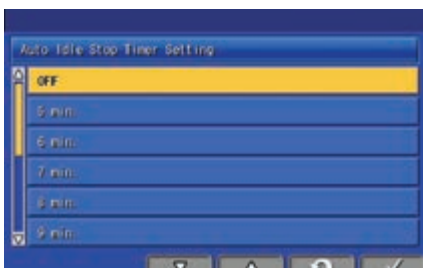
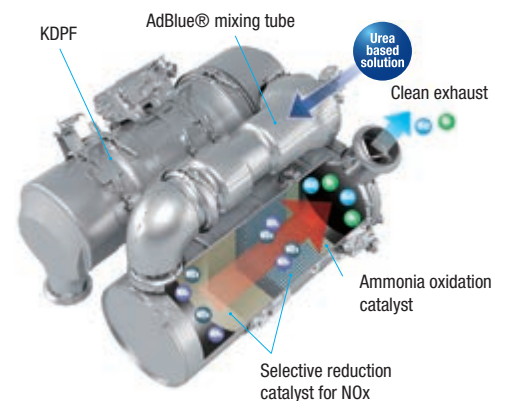

Adjustable idle shutdown automatically turns off the engine after it idles for a set period of time

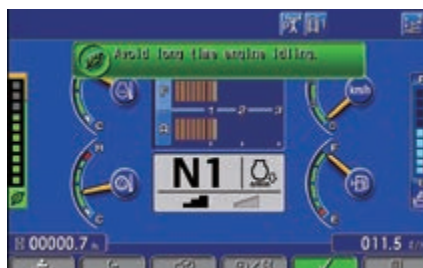

Eco-gauge, Eco guidance and fuel consumption gauge



Fuel consumption history

Optimised Work Equipment

Komatsu blades

For increased blade performance and better machine balance, Komatsu uses a box blade design, with the highest resistance for a light weight blade. Special Komatsu highly wear resistant steel is used for the front and sides of the blade to increase durability. The deep curved design of the blade makes it easy to handle a wide range of materials, with good penetration and a large capacity, optimising high dozing performance with excellent fuel efficiency.

Komatsu rippers

Komatsu rippers were designed to combine the highest productivity with a long lifetime. The shank is fitted with special wear parts that increase longevity, and offer the best penetration in various types of materials.

Multishank parallelogram ripper (option)

The multishank parallelogram ripper has 3 ripper shanks as standard, but can be easily converted to a single or two-shank ripper, depending on job conditions. The strong parallelogram design offers straight shank movement, adapted for tough applications.

Straight Power Angle Tilt blade with adjustable pitch

The straight Power Angle Tilt blade (PAT), offers a wide range of working modes. The large diameter centreball design offers a strong and durable solution for the blade attachment to the Inpat frame reducing maintenance costs. A fold-up INPAT version of the blade for the PX machines guarantees a transport width of 3 metres and easy transportation between job-sites.

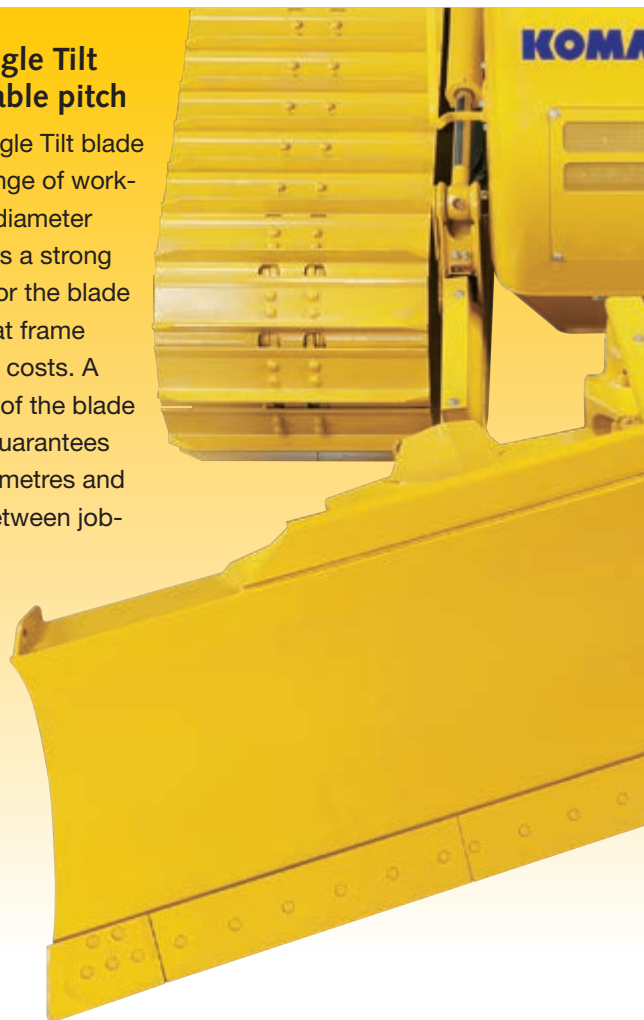



First-Class Comfort

Quiet and comfortable cab

Operator comfort is essential for safe and productive work. The cab on the D61-24 is quiet and comfortable, an ideal environment to concentrate on the job. Its hexagonal design and large tinted glass windows offer excellent panoramic visibility. The high capacity climate control system pressurises the cab to keep dust out. A high quality sound-absorbent lining covers the interior to minimise noise levels for the operator.

The best view

A super slant nose gives the D61-24 the best visibility of any dozers on the market. This unique feature dramatically increases efficiency and jobsite safety, with operators now always having full view of both the blade and the ripper and of objects close to them. The new cab-forward design, with integrated ROPS/FOPS and large glass windows, provides more room and places the operator closer to the blade, further improving visibility and comfort.

Fully-adjustable, heated air suspension seat

The driver's seat and console are amongst the most important components of the driver's equipment. The comfortable, heavy-duty, air suspension seat, complete with headrest, gives the operator a secure and comfortable work environment.



D61EX/PX-24

State-of-the-Art Controls



Large TFT colour multi monitor

A large user-friendly colour monitor enables safe, accurate and smooth work. It provides on-hand data to continuously improve productivity and fuel consumption. Multilingual and with all essential information available at a glance, it features simple and easy to operate switches and multifunction keys that provide the operator with fingertip access to a wide range of functions and operating information.

Automatic speed change

Komatsu HST controller always changes the travel speed automatically, depending on load or ground conditions, and efficient operations are facilitated – with no shift shocks. The dozer can work at the optimal speed and drawbar pull point, increasing productivity and fuel efficiency.

Easy operation control

The ergonomic Palm Command Control System (PCCS) provides efficient and comfortable steering of the machine, and the blade control joystick utilizes Proportional Pressure Control (PPC) for precise operations, excellent and easy grading jobs - and improved productivity.

Selectable working modes

Working mode can be set to either “Power” for maximum power or to “Economy” for energy saving operations. Combined with a choice between automatic or manual working mode, this lets the operator select the optimum machine power configuration for the work at hand.



Palm Command Control System (PCCS)



Combined decelerator/brake pedal



Fully integrated rear-view camera system

Information & Communication Technology



Lower operating costs

Komatsu ICT contributes to the reduction of operating costs by assisting to comfortably and efficiently manage operations. It raises the level of customer satisfaction and the competitive edge of our products.

Widescreen monitor

Conveniently customisable and with a choice of 26 languages, the wide-screen monitor with simple switches and multifunction keys gives fingertip access to a large range of functions and operating info. An AdBlue® level gauge is now incorporated into the default main screen.

An evolutionary interface

Helpful information is now easier than ever to find and understand with the upgraded monitor interface. The main screen can be simply optimised to the operator's preference by just pressing one button.



Quick view on the operation logs



All information at a glance

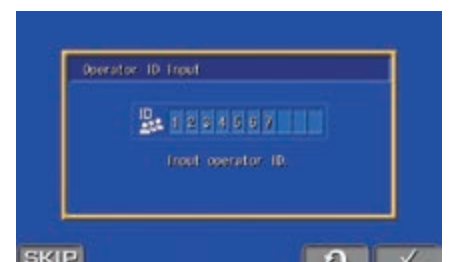

Operator identification function

KOMTRAX™

The way to higher productivity

KOMTRAX™ uses the latest wireless monitoring technology. Compatible on PC, smartphone or tablet, it delivers insightful and cost saving information about your fleet and equipment, and offers a wealth of information to facilitate peak machine performance. By creating a tightly integrated web of support it allows proactive and preventive maintenance and helps to efficiently run a business.



Knowledge

You get quick answers to basic and critical questions about your machines – what they're doing, when they did it, where they're located, how they can be used more efficiently and when they need to be serviced. Performance data is relayed by wireless communication technology (Satellite, GPRS or 3G depending on model) from the machine to a computer and to the local Komatsu distributor – who's readily available for expert analysis and feedback.

Power

The detailed information that KOMTRAX™ puts at your fingertips 24 hours a day, 7 days a week gives the power to make better daily and long-term strategic decisions – at no extra cost. Problems can be anticipated, maintenance schedules customised, downtime minimised and machines kept where they belong: working on the jobsite.

Convenience

KOMTRAX™ enables convenient fleet management on the web, wherever you are. Data is analysed and packaged specifically for effortless and intuitive viewing in maps, lists, graphs and charts. You can foresee eventual maintenance issues and required spare parts, and troubleshoot a problem before Komatsu technicians arrive on site.



Easy Maintenance



Reversible swing-up fan

The D61-24 includes a swing-up fan with a gas strut-assisted lift locking system to provide easy access to the radiator, oil cooler, and charge air cooler. The operator can switch the hydraulic fan to “cleaning” mode so that it rotates in reverse at full speed to clean the radiators, reducing maintenance costs and improving fuel efficiency.



Simple and convenient service

Well located service doors allow convenient and safer ground access to daily service points. With the radiator located at the rear of the machine, engine fuel and oil filters can be easily accessed from the front of the engine compartment. Remote grease points facilitate lubrication of the C-frame pivots and angle cylinder bearing.



Self-diagnostic monitor

The multifunction monitor panel displays the running time, engine revs, fuel level and water coolant temperature in real time. It also provides the operator with maintenance and service information, if oil filters need replacing or any abnormality occurs. In addition, it supplies Komatsu mechanics with detailed information, with no need for external service tools.

Komatsu CARE™

Komatsu CARE™ is a complimentary maintenance program that comes as standard with



your new Komatsu machine. For the first 3 years or 2,000 hours it covers factory-scheduled maintenance, performed by Komatsu-trained technicians with Komatsu Genuine parts. It also offers up to a maximum of 2 complimentary Komatsu Diesel Particulate Filter (KDPF) exchange units and a warranty for 5 years or 9,000 hours for the KDPF and Selective Catalytic Reduction (SCR) unit.

Modular power train

All the power train components are enclosed in a sealed module. This eliminates oil spills during mounting and dismounting, and prevents dust and dirt polluting individual components. Servicing is much cleaner, smoother and easier.

AdBlue® tank

The AdBlue® tank is easily accessible on the left hand side of the machine.



Tough and Reliable

Low-drive "PLUS" undercarriage

Komatsu's low-drive Parallel Link Undercarriage System (PLUS) is extraordinarily tough, with excellent grading performance and stability. It features PLUS link assemblies, a highly reliable floating bushing concept, substantial track link height, superior oil seals and track guards that maximise undercarriage durability. For easier servicing, the equaliser bar's centre pin is remotely greased. The segmented sprockets are notched to considerably improve the evacuation of mud and further increase the PLUS undercarriage lifetime.

EX undercarriage

The EX undercarriage has been specially designed for working on hard ground. The small to medium-width shoes and PLUS link assembly ensure a large contact area between the machine and the ground for maximum stability, grading performance and undercarriage lifetime.

PX undercarriage

The PX undercarriage is ideal for working on soft surfaces. The wide shoes and PLUS link assembly ensure a large contact area between the machine and the ground for maximum stability, grading performance and undercarriage lifetime.

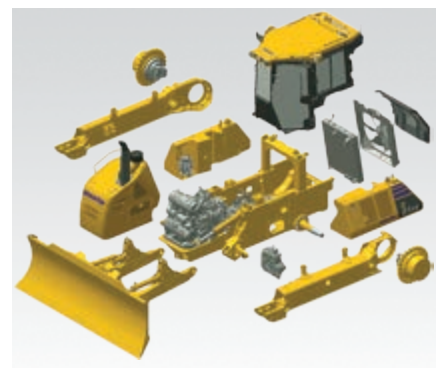
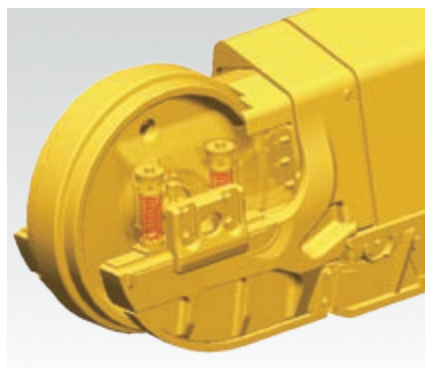

Self-adjusting idler support

The self-adjusting idler support provides constant and even tension on idler guide plates. It reduces noise levels and vibrations and increases undercarriage life.

Modular design

D61-24 was designed and manufactured to have low maintenance costs and a long lifetime. This was achieved mainly by reducing component complexity and with a strong modular design.

Specifications

ENGINE

Model	Komatsu SAA6D107E-3
Type	Common rail direct injection, water-cooled, emissionised, turbocharged, after-cooled diesel
Engine power	
at rated engine speed	2.200 rpm
ISO 14396	126 kW/169 HP
ISO 9249 (net engine power)	125 kW/168 HP
No. of cylinders	6
Bore × stroke	107 mm × 124 mm
Displacement	6,69 l
Fan drive type	Hydraulic, reversible
Lubrication system	
Method	Gear pump, force lubrication
Filter	Full flow

HYDROSTATIC TRANSMISSION

Dual-path, hydrostatic transmission provides infinite speed changes up to 9,0 km/h. The variable capacity travel motors allow the operator to select the optimum speed to match specific jobs. Travel control lock lever and neutral switch.

MAX. TRAVEL SPEEDS (EX/PX)

Quick shift mode	Forward	Reverse
1st	0 - 3,4 km/h	0 - 4,1 km/h
2nd	0 - 5,6 km/h	0 - 6,5 km/h
3rd	0 - 9,0 km/h	0 - 9,0 km/h
Variable speed mode	Forward	Reverse
	0 - 9,0 km/h	0 - 9,0 km/h

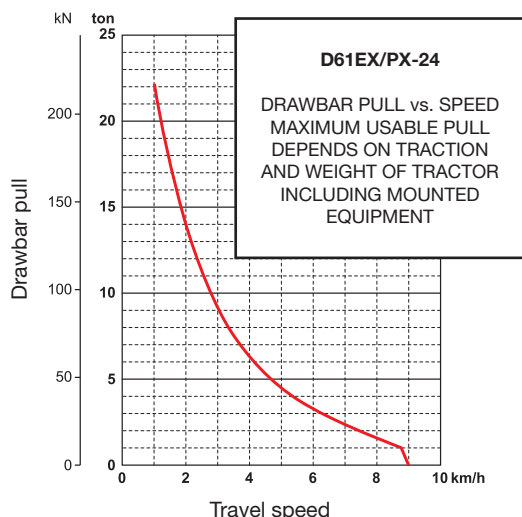

SERVICE REFILL CAPACITIES

Fuel tank	372 l
Radiator	45 l
Engine oil	27 l
Hydraulic tank	101 l
Final drive (each side)	8,1 l
AdBlue® tank	20 l

STEERING SYSTEM

Type	Hydrostatic Steering System (HSS)
Steering control	PCCS-lever
Minimum turning radius (counter-rotation) as measured by track marks on ground	
D61EX-24	2,1 m
D61PX-24	2,3 m

UNDERCARRIAGE

Suspension	Oscillating equaliser bar and pivot shaft
Track roller frame	Monocoque, large section, durable construction
Tracks	PLUS link assembly
Track tension	Combined spring and hydraulic unit
Number of shoes (each side)	46
Grouser height (single grouser)	58 mm
Track rollers (each side)	8
Carrier rollers (each side)	2
Shoe width (standard)	
D61EX-24	600 mm
D61PX-24	860 mm
Ground contact area	
D61EX-24	37.980 cm ²
D61PX-24	54.440 cm ²
Ground pressure	
D61EX-24	0,47 kg/cm ²
D61PX-24	0,34 kg/cm ²

OPERATING WEIGHT (APPR.)

Including PAT blade, steel cab, operator, rated capacity of lubricant, coolant, and full fuel tank.

D61EX-24	18.520 kg
D61PX-24	19.460 kg

ENVIRONMENT

Engine emissions Fully complies with EU Stage IV exhaust emission regulations

Noise levels

LwA external	107 dB(A) (2000/14/EC Stage II)
LpA operator ear	78 dB(A) (ISO 6396 dynamic test)

Vibration levels (EN 12096:1997)*

Hand/arm (EX)	≤ 2,5 m/s ² (uncertainty K = 1,10 m/s ²)
Hand/arm (PX)	≤ 2,5 m/s ² (uncertainty K = 0,79 m/s ²)
Body (EX)	≤ 0,5 m/s ² (uncertainty K = 0,24 m/s ²)
Body (PX)	≤ 0,5 m/s ² (uncertainty K = 0,19 m/s ²)

* For the purpose of risk assessment under directive 2002/44/EC, please refer to ISO/TR 25398:2006.

FINAL DRIVE

Type	Spur and planetary gear, double-reduction
Sprocket	Segmented sprocket teeth are bolt-on for easy replacement

DIMENSIONS

	D61EX-24	D61PX-24
A	3.250 mm	3.860 mm
B	435 mm	515 mm
C	1.195 mm	1.155 mm
D	1.025 mm	1.025 mm
E	580 mm	580 mm
F	3.165 mm	3.165 mm
G	5.480 mm	5.480 mm
H	3.180 mm	3.180 mm
I	58 mm	58 mm
J	1.900 mm	2.130 mm
K	600 mm	860 mm
L	2.500 mm	2.990 mm
M	2.980 mm	3.530 mm
N	6.100 mm	6.220 mm

Ground clearance: 390 mm

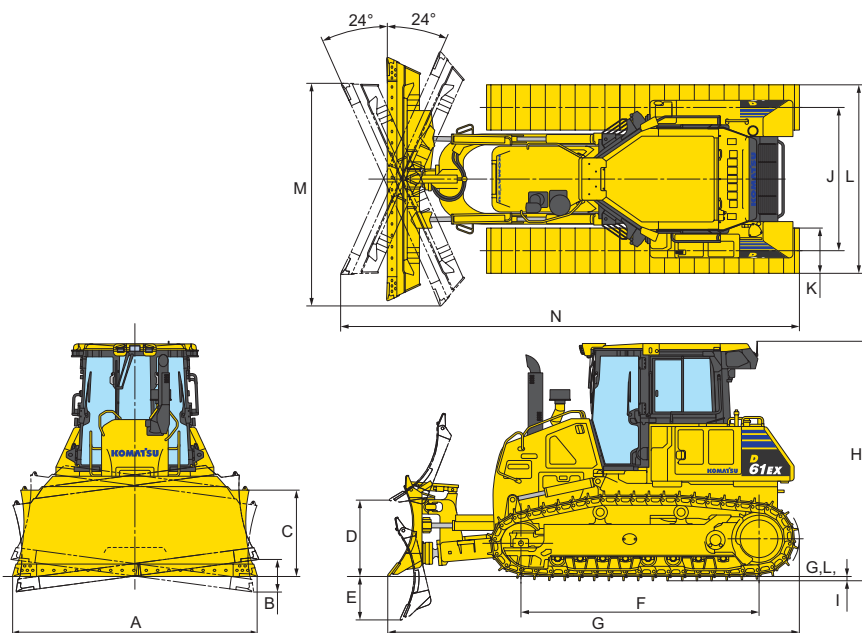

HYDRAULIC SYSTEM

Type	CLSS (closed-centre load sensing system)
All spool valves externally mounted beside the hydraulic tank.	
Maximum pump flow	171 l/min
Relief valve setting	280 kg/cm ²
Spool control valve positions	
Blade lift	Raise, hold, lower, and float
Blade tilt & angle	Right, hold, and left
Additional control valve positions for ripper	
Ripper lift	Raise, hold, and lower
Hydraulic cylinders	Double-acting, piston
No. of cylinders × bore	
Blade lift	2 × 100 mm
Blade tilt	1 × 120 mm
Blade angle	2 × 110 mm

MULTISHANK RIPPER (EX)

Type	Hydraulically controlled parallelogram ripper
No. of shanks	3
Weight (including hydraulic control unit)	1.780 kg
Beam length	2.170 mm
Maximum lift above ground	560 mm
Maximum digging depth	665 mm

DOZER EQUIPMENT

	Overall length with dozer	Blade width × height	Maximum lift above ground	Maximum drop below ground	Maximum tilt adjustment	Additional weight
3,4 m ³ PAT blade (EX)	5.480 mm	3.250 mm × 1.195 mm	1.025 mm	580 mm	435 mm	0 kg
3,8 m ³ PAT blade (std. PX, opt. EX)	5.480 mm	3.860 mm × 1.155 mm	1.025 mm	580 mm	515 mm	0 kg
3,8 m ³ foldable PAT blade (PX)*	5.480 mm	3.860 mm × 1.155 mm Folding width: 2.960 mm	1.025 mm	580 mm	515 mm	+ 260 kg

Blade capacities are based on the SAE recommended practice J1265.

* Applicable only to light duty jobs.

Standard and Optional Equipment

ENGINE AND RELATED PARTS

Komatsu SAA6D107E-3 turbocharged common rail direct injection diesel engine	●
EU Stage IV compliant	●
Alternator 24 V/90 A	●
Starter motor 5,5 kW/24 V	●
Batteries 170 Ah/2 × 12 V	●
Cooling fan, hydrostatic driven with reversing function	●
Fuel tank inlet strainer	●
Fuel pre-filter (10 micron) and fuel filter (2 micron)	●
Exhaust pipe with elbow	●
Intake pipe with rain cap	●
Intake pipe with air pre-cleaner	○

TRANSMISSION AND BRAKES

Electronically controlled HST	●
Palm lever steering control (PCCS)	●
Quick shift selection system	●
Variable speed mode	●
Reverse speed presets	●
Combined decelerator/brake pedal	●

UNDERCARRIAGE

Komatsu PLUS link assembly	●
Single grouser heavy-duty shoes (EX: 600 mm; PX: 860 mm)	●
Segmented sprockets	●
Idler cushions	●
Track roller guard, centre and end section	●
Full length track roller guard	○

HYDRAULIC SYSTEM

Hydraulics for dozing blades	●
Mono lever blade control	●
Hydraulics for ripper	●

SERVICE AND MAINTENANCE

Dry type air cleaner, double element with dust indicator and evacuator	●
Water separator	●
Multi-function video compatible colour monitor with Equipment Management and Monitoring System (EMMS) and efficiency guidance	●
KOMTRAX™ – Komatsu wireless monitoring system (3G)	●
Komatsu CARE™ – complimentary maintenance program for customers	●
Tool kit	●

CABIN

Air suspension seat: fabric, reclining, heated, high backrest	●
Seat belt with visible alert	●
High mount footrest	●
Air conditioner	●
Radio	●
Auxiliary input (MP3 jack)	●
2 × 12 Volt power supply (120 W)	●
1 × 24 Volt power supply	●
Viscous cab mounts	●
Rear-view mirror (inside cab)	●
Wiper front window	●
Wiper rear window	●
Wipers doors	●
Heated rear window	●
Cup holder	●
Lunch box holder	●

LIGHTING SYSTEM

Working lights, 3 cab roof front, 2 cab roof rear	●
---	---

SAFETY EQUIPMENT

Steel cab, meets ISO 3471 and SAE J1040, APR88 ROPS standards, as well as ISO 3449 FOPS standards	●
Horn	●
Locks, filter caps and covers	●
Back-up alarm	●
Rear view camera system	●
Fire extinguisher	○

ATTACHMENTS

Front pull hook	●
Hitch (not with ripper)	●
Multishank parallelogram ripper (EX)	○
Rigid drawbar	○

DOZER EQUIPMENT

3,4 m³ PAT blade (EX)	●
3,8 m³ PAT blade (PX)	●
3,8 m³ PAT blade foldable (PX)	○

Further equipment on request

- standard equipment
- optional equipment

Your Komatsu partner:

KOMATSU

**Komatsu Europe
International N.V.**

Mechelsesteenweg 586
B-1800 VILVOORDE (BELGIUM)
Tel. +32-2-255 24 11
Fax +32-2-252 19 81
www.komatsu.eu