

KOMATSU

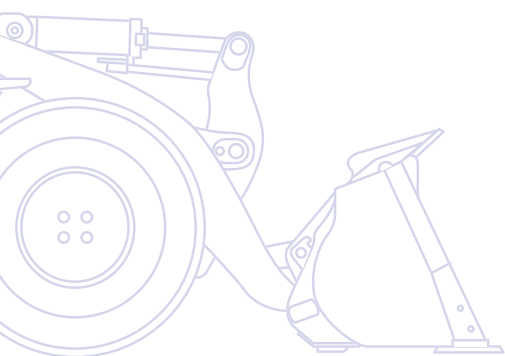

Wheel Loader **WA480-6**



ENGINE POWER
224 kW / 300 HP @ 2.000 rpm

OPERATING WEIGHT
25.140 - 25.605 kg

BUCKET CAPACITY
4,5 - 5,0 m³

Walk-Around

Efficient and productive, the WA480-6 wheel loader features Komatsu's advanced power-train technology and a top-performance engine that delivers high power and torque at low revs. Whatever the job, the WA480-6 will handle it with excellent fuel efficiency thanks to an outstanding tractive force and Komatsu's Closed Load Sensing System (CLSS) hydraulics. Its exclusive SpaceCab™ offers unrivalled operator comfort and an excellent view of the bucket and wheels. Reliability, economy, safety and ease of service – the WA480-6 sets new standards for this class of wheel loaders.



High productivity & low fuel consumption

- High-torque and low-consumption ecot3 Komatsu engine
- Meets EU Stage IIIA and EPA Tier III
- High-capacity torque converter
- Torque converter lock-up (option)
- Automatic transmission with mode selection

Excellent stability and manoeuvrability

- Superior dumping height and reach
- Wide tread and long wheelbase
- Boom suspension system for minimum spillage
- Komatsu CLSS hydraulic system

WA480-6

ENGINE POWER
224 kW / 300 HP @ 2.000 rpm

OPERATING WEIGHT
25.140 - 25.605 kg

BUCKET CAPACITY
4,5 - 5,0 m³



First-class operator comfort

- Two-door SpaceCab™
- Outstanding 360° visibility
- Deluxe heated, air-suspended driver seat
- Large armrest and adjustable console
- Electronically controlled air conditioning

Easy maintenance

- Wide core radiator with auto reversible fan speeds up cleaning
- Factory fitted automatic lubrication system
- Large gull-wing doors for easy access to service points
- Equipment Management and Monitoring System (EMMS)
- Robust components with a long service life



- *Low Consumption, especially in*
- *Load & Carry with*
- *Large Converter*

Simple & convenient handling

- Smooth ergonomic hydraulic control
- Multi-function lever (option)
- Intelligent gas pedal
- Joystick steering (option)

KOMTRAX

Komatsu Satellite
Monitoring System

High Productivity & Low Fuel Consumption

Low consumption ecot3 engine

The Komatsu SAA6D125E-5 engine provides high torque, a better performance at low speed and low fuel consumption. This ecot3 engine features a new combustion chamber design with optimised ignition and combustion timing. The operating pressure of the new common rail system was increased for improved injection and fuel efficiency. The air-to-air intercooler reduces the temperature of the compressed air supplied by the turbo charger to the cylinders, and further improves fuel consumption. The engine reaches its max. performance of 235 kW at already 1.700 rpm.

Advanced Komatsu power train design

With its high-capacity torque converter, the completely redesigned Komatsu drive train offers optimum efficiency and an unparalleled rimpull-to-weight ratio. By delivering high rimpull at low speeds, it makes child's play of heavy jobs like penetration of dense material such as aggregate. This means higher productivity in V-Shape loading, even in confined spaces. For Load & Carry applications, the WA480-6 also has plenty of acceleration and can achieve high speeds, even on grades or steep ramps leading to feed hoppers.

Meets EU Stage IIIA

The new Komatsu ecot3 engine technology reduces NOx and particle emissions, fuel consumption and noise level. The Komatsu SAA6D125E-5 is certified for EPA Tier III and EU Stage IIIA emission regulations.

Automatic transmission with mode selection

The operator can select manual shifting or has the choice between two levels of automatic shifting. Auto "Low" mode keeps the engine in a lower rpm range for fuel efficiency while also giving tractive force at the touch of the accelerator pedal. Auto "High" mode will set the gear shift timing at higher speeds.

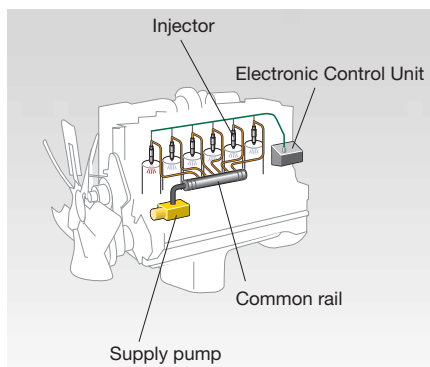

High pressure common rail fuel injection

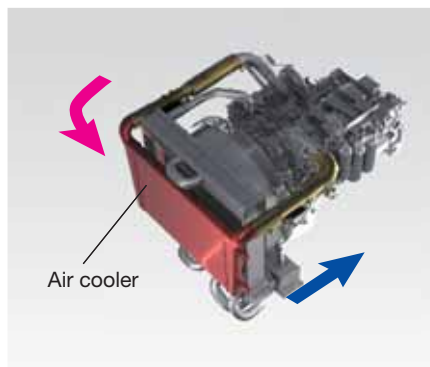

Air-to-air charge air cooling system

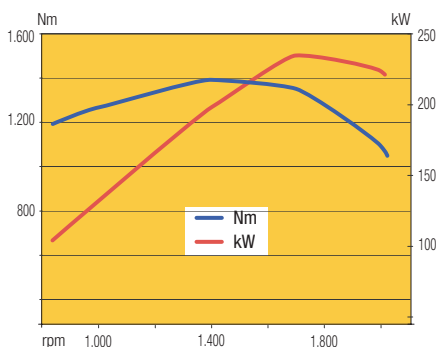



Faster load & carry

The optional new sequential torque converter lockup system delivers unbeatable productivity and fuel efficiency in load & carry and short distance transport applications. The operator can engage the system from 2nd to 4th gear. It noticeably increases travel speed, particularly when going uphill, thanks to the larger tractive force. It also significantly reduces fuel consumption by eliminating converter losses.



Excellent Stability and Manoeuvrability

Wide tread and long wheelbase

A 2.300 mm wide tread and a long wheel base of 3.450 mm give the WA480-6 outstanding stability – enough to handle rough terrain and fast load & carry cycles with minimum spillage and maximum comfort. With 37° steering articulation to both sides, the WA480-6 is extremely manoeuvrable in tight spaces for faster loading cycles.

Superior dumping height and reach

The long lifting frame allows an enormous dumping height of 3.160 mm and a reach of 1.375 mm that is just as impressive (with a 4,8 m³ universal bucket, measured to the cutting edge). With this working range, loading high feeders or trucks becomes easy and fast.

Precision control

Komatsu's CLSS hydraulics enables extremely precise control of the work equipment, and ensures that the bucket, boom and hydraulically driven attachments can all move smoothly at the same time. The WA480-6 also features variable-displacement pumps on both the hydraulic and steering systems. These pumps deliver the exact amount of oil required, dramatically improving fuel efficiency.





Boom suspension system

The boom suspension system reduces the shocks in the boom when driving with loads. Material can be transported at higher speeds with minimum spillage. When travelling below 7 km/h, the boom suspension is automatically deactivated for precise pallet loading into trucks.



Simple & Convenient Handling

Smooth ergonomic hydraulic control – EPC option

The new control levers are fingertip controlled for precise and fatigue-free operating. The position of the levers and of the entire console can be adjusted to suit any operator. EPC equipment for controlling the hydraulic system is also available in option. It offers a vibration-free modulating function for slowing and stopping bucket movements when lowering. For major ease of operation the upper and lower boom cut-out position can be pre-set with a switch. As a third feature, EPC equipment has a semiautomatic excavating function for simple filling of buckets.

PPC-Multifunction lever (option)

The servo-assisted multi-function lever with an integrated forward/reverse switch allows the simplest and most comfortable operation of the equipment. With one hand the driver can simultaneously control the attachment and switch between forward and reverse. The multi-function lever is the perfect choice for earth moving jobs.

Intelligent gas pedal

Our innovative new thrust-sensing gas pedal automatically helps the operator match the timing of gear shifts to the load. In heavy-duty work, requiring high rimpull and maximum acceleration, the operator tends to press heavily on the gas pedal. The machine anticipates this and shifts up gears as late as possible. In light-duty work, where fuel consumption is a major factor, the operator will intuitively press the gas pedal lightly. Again, the machine anticipates this – and shifts up gears as early as possible to achieve the best fuel efficiency.

New and easy-to-use joystick steering (option)

A new joystick steering system is available in option. It allows gear shifting with push buttons and ensures that steering can be wrist operated easily and conveniently when loading. You may pre-select the steering speed in 2 stages, depending upon whether fast V-loading or precise load & carry is required.





First-Class Operator Comfort

Large SpaceCab™

Komatsu's SpaceCab™ is among the most spacious in its class and it has been lengthened for greater leg room. It offers a driving convenience comparable to that of a passenger car. The cabin is mounted on viscose shock absorbers that guarantee low vibrations and sound levels.

Outstanding 360° visibility

The large frameless windscreen ensures an optimum view of the bucket and tyres. The slanted engine hood gives an excellent view to the rear.

Air-suspended, heated seat

The high comfort air-suspended seat, with lumbar support and multiple possibilities for adjustments, ensures the operator's well being during the entire working day. All seats are equipped with a heating function to provide an easy start on cold days.



Electronically controlled air conditioning

With the electronically controlled air conditioning fitted as standard, the operator can feel at ease regardless of the outside temperature. Concentration and productivity stays high all day.

Additional comfort

Further standard features of the Komatsu SpaceCab™ are the CD radio, a "hot and cool" box for beverages, several storage spaces and adjustable arm rests on both sides.

Safe, convenient access

For easy and safe entry, on each side of the cabin the WA480-6 has an access ladder with self-cleaning, anti-slip steps inclined forward at 8°. The cab doors are hinged at the rear for the widest possible opening angle.





Easy Maintenance

Easy access to service points

For easy and safe opening the gull-wing doors are supported by gas springs. The large doors give a convenient access from ground level to all daily service points. With long service intervals and all filters collected in a centralised arrangement, machine downtime is reduced to a minimum.

State-of-the-art monitoring

The equipment management and monitoring system (EMMS) is clearly structured and easy to read. If a malfunction occurs, it is immediately displayed as plain text in the selected language. The system features an error memory, a self-diagnosis function and a display of service intervals. The EMMS gives timely notification of required oil and filter replacements. All information can also be accessed off-site via KOMTRAX™. The operator and customer service engineer are constantly informed about the machine's state so that problems can be prevented before they occur.

Auto reverse fan

To minimize manual cleaning, a reversible fan blows dust out, automatically or on demand. The "automatic reverse" function allows to set the cleaning length interval to perfectly adjust to the working conditions.

Factory fitted automatic lubrication system

The automatic lubrication system reduces the daily service work to the absolute minimum. Robust piping ensures consistent lubrication and operating reliability, and significantly increases the machine's service life. The system is electronically monitored and features a signal light in the cabin.

Customer service and spare parts supply

When you buy Komatsu, you buy a lot more than just a machine. Our service support accompanies you throughout the entire life of your wheel loader. Programs for preventative maintenance are as much a part of the offer as the complete range of dealer services and repair programmes. In case of malfunction, Komatsu's close-knit network of dealers and excellent parts service ensures minimum machine downtime.



Auto reverse fan



Automatic central lubrication



EMMS (Equipment Management Monitoring System)



Easy access to service points



Komatsu Satellite Monitoring System



KOMTRAX™ is a revolutionary machine tracking system designed to save you time and money. You can now monitor your equipment anytime and anywhere. Use valuable machine data received via the KOMTRAX™ web site to optimise your maintenance planning and machine performances.

KOMTRAX™ can assist you with:

Full machine monitoring

Get detailed operation data to know when your machines are used and how productive they are.

Total Fleet Management

Keep track of the location of your machines at all times and discourage unapproved usage or theft.

Complete machine status

Receive warnings, alerts and cautions, via a web site or by e-mail, to help with maintenance planning and for longer machine life.

For further details on KOMTRAX™, please ask your Komatsu dealer for the latest KOMTRAX™ brochure.





Machine working time - With the "daily working record" chart, get precise engine running time data: when your machine was started and when it was shut down, as well as total engine running time.



Maintenance planning - To increase productivity and improve maintenance planning, alerts indicate when items such as filters or oil must be replaced.



Fleet location - The machine list instantly locates all your machines, even those in other countries.



Machine tracking during transport - When your machine is transported, KOMTRAX™ sends travel messages to the web site or by e-mail to inform you of its progress, and confirms when it reaches its destination.



Alarm notifications - You can receive notification of alarms both via the KOMTRAX™ website and by e-mail.



Added security - The "engine lock" feature allows to program when a machine's engine can be started. And with "geo-fence", KOMTRAX™ sends notification every time your machine moves in or out of a predetermined operating area.



Robust and Reliable

Designed and built by Komatsu

The engine, hydraulics, power train, front and rear axles are original Komatsu components. All these components are subject to the highest quality standards right down to the smallest screw. All components are fully co-ordinated with one another, thus offering the maximum efficiency and reliability.

Heavy-duty axles

The heavy-duty axles allow exceptional service life even under the toughest working conditions. The optional limited slip differentials are most suitable for soft and slippery ground like sand or wet soil.

Wet multi-disc service brake

The multi-disc service brake is encapsulated and runs in an oil bath. The brake stays clean and operates at low temperature for increased service intervals and a long lifetime.

Robust torsion-resistant main frame

The frame design with hinge points far apart guarantees the high stability for the overall construction and reduces bearing stress in the torsional ranges.

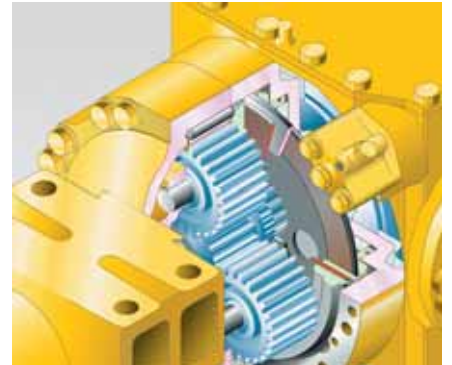



Tailored Solutions

Working gear division

Komatsu wheel loaders combined with a wide range of genuine Komatsu attachments provide the perfect solution for any industry sector. For special applications our “Working Gear” division offers purpose-built machines and attachments. The tailor made solutions allow high performance and outstanding reliability even under toughest conditions.



Waste handling

We adapt our wheel loaders to the different conditions that exist on waste handling job sites. Along with heavy duty attachments, we offer solutions to protect your machine against damage.



Timber industry

A wide range of options specifically developed for the timber industry are available: log grapples, wood chip buckets, cameras, as well as various protections and pre-filters.



Scoria applications

One of the hardest jobs for wheel loaders is in steel mills. Heat, dust and confined space require an optimum customizing of the base machine with extra features such as heat protected hoses, armoured glass, or bottom plates.





Buckets and Attachments



Universal bucket

This type of bucket is impressive because of its excellent penetration and loosening properties and its good material holding properties. This universal bucket can be equipped with flush mount adapters and interchangeable teeth.



Earthmoving bucket

The earthmoving bucket with a one-piece bucket bottom is suited both for earthworks and loading cohesive material. The slanted sides give powerful penetration. It is equipped either with flush mount adapters and interchangeable teeth or also with a rear removable edge.



Stock pile bucket

The stock pile bucket is the right solution for handling loose and relatively light materials. The straight sidewalls ensure a high bucket capacity, the rear edge makes levelling and cleaning up jobsites easy. This stock pile bucket can be equipped with flush mount adapters and interchangeable teeth or a bolt-on cutting edge.



Stock pile bucket with raised bottom

The stock pile bucket with raised bottom is the right solution for handling loose and relatively light materials on paved grounds. The combination of rounded shovel back and the straight sidewalls contributes to good filling properties and less material spillage.



Hydraulic quick coupler

The WA480-6 can change attachments in a matter of seconds with a market compatible or HD wedge type quick coupler. With the wedge type quick coupler, featuring a unique and innovative design, the offset to the original connection points is reduced to a minimum. Thus, lifting forces remain almost the same compared to a direct mounted bucket.



A comprehensive range of attachments

The log grapple: With its sturdy structure and its great hydraulic power and a special tilting cylinder, the WA480-6 is also perfectly suited to work in the timber industry. The robust design of the lifting frame and axles ensures maximum durability.

ENGINE

Model Komatsu SAA6D125E-5
Common rail direct injection, water-cooled, emissionised, turbocharged, after-cooled diesel

Engine power
at rated engine speed 2.000 rpm
ISO 14396 224 kW / 300 HP
ISO 9249 (net engine power) 223 kW / 299 HP

Max. torque / engine speed 1.390 Nm / 1.400 rpm

No. of cylinders 6

Bore × stroke 125 × 150 mm

Displacement 11,04 ltr

Fan drive type Hydraulic

Lubricating system Gear pump, water-cooled oil cooler, piston cooling nozzles

Filter Main-flow filter with water separator

Air-filter type Dry-air filter with automatic dust emission and preliminary purification including a dust display

TRANSMISSION

Type Automatic powershift transmission

Torque converter One-stage, one-phase, 3-element

Speeds in km/h (with 26.5 R25 tyres)

Gear	1.	2.	3.	4.
Forward	7,6	13,2	22,7	36,2
with torque converter lock-up	–	13,5	23,6	39
Reverse	7,9	13,5	23,5	37,3
with torque converter lock-up	–	13,8	24,3	39

CHASSIS AND TYRES

System 4-wheel drive

Front axle Komatsu HD axle, semi-floating, (LSD-differential optional)

Rear axle Komatsu HD axle, semi-floating, 26° swing angle (LSD-differential optional)

Differential Straight bevel gear pair

Final drive Planetary gear in an oil bath

Tyres 26.5 R25

SERVICE REFILL CAPACITIES

Cooling system 60 ltr

Fuel tank 413 ltr

Engine oil 38 ltr

Hydraulic system 173 ltr

Front axle 60 ltr

Rear axle 56 ltr

Torque converter and transmission 65 ltr

BRAKES

Operating brakes Hydraulically actuated, wet multi-disc brakes on all wheels

Parking brake Wet multi-disc

Emergency brake Uses the parking brake

HYDRAULIC SYSTEM

Type Komatsu CLSS (Closed Centre Load Sensing System)

Hydraulic pump Variable piston pump

Working pressure 350 bar

Maximum pump flow 260 ltr/min

No. of hydraulic/bucket cylinders 2/1

Type Double-action

Bore diameter × stroke

Boom cylinder 140 × 881 mm

Bucket cylinder 180 × 572 mm

Hydraulic cycle with rated load bucket filling

Raise time 5,9 s

Lowering time (empty) 3,5 s

Dumping time 1,9 s

STEERING SYSTEM

System Articulated frame steering

Type Completely hydraulic power steering

Steering angle to either side 37°

Steering pump Variable piston pump

Working pressure 250 bar

Pumping capacity 195 ltr/min

No. of steering cylinders 2

Type Double-action

Bore diameter × stroke 90 × 441 mm

Smallest turn (outer edge of the tyre 26.5 R25) 7.000 mm

CABIN

Two-door SpaceCab™ in conformity with ISO 3471 with ROPS (roll over protective structure) in conformity with SAE J1040c and FOPS (falling object protective structure) in conformity with ISO 3449. The air-conditioned pressurised cabin is mounted upon hydrobearings and is noise dampened.

ENVIRONMENT

Engine emissions Fully complies with EU Stage IIIA and EPA Tier III exhaust emission regulations

Noise levels

LwA external 108 dB(A) (2000/14/EC Stage II)

LpA operator ear 73 dB(A) (ISO 6396 dynamic test)

Dimensions & Performance Figures

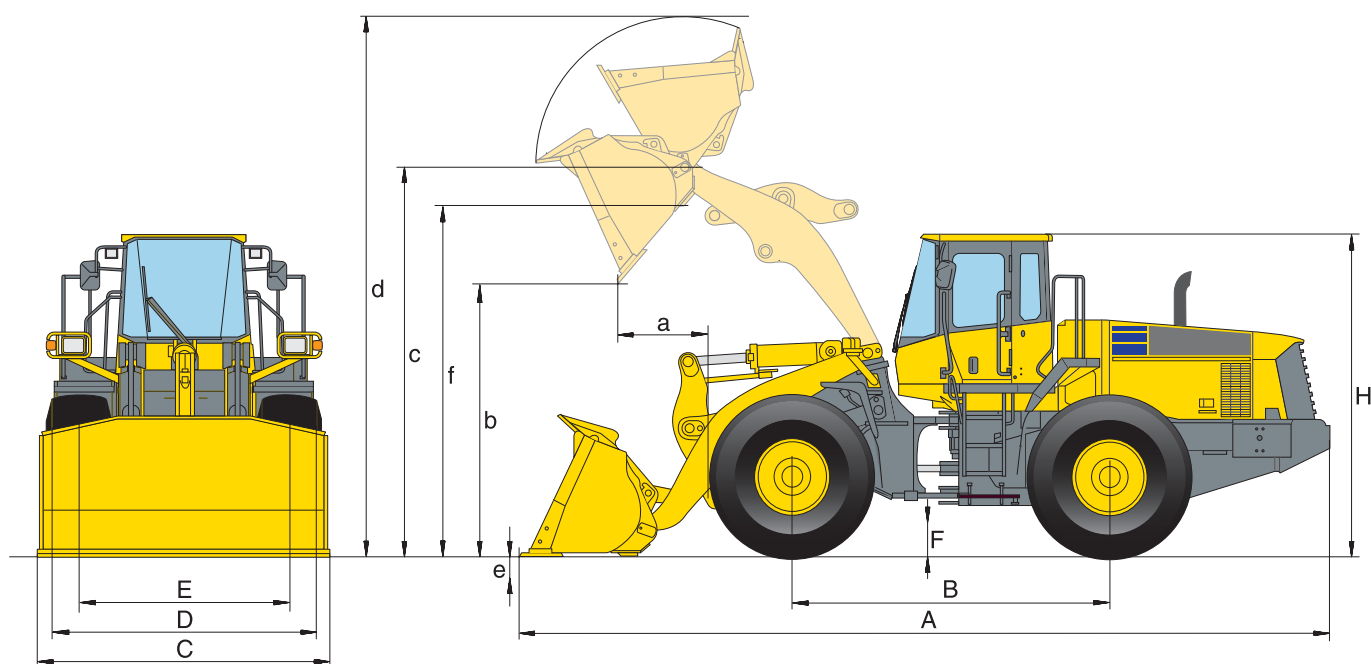

MEASUREMENTS AND WORKING SPECIFICATIONS

Bucket type		Earthmoving			Stock pile with flat bottom	
		w.teeth	with BOC	w/o teeth	w.teeth	with BOC
Bucket capacity (heaped, ISO 7546)	m ³	4,5	4,65	4,9	4,9	5,0
Sales code	3967	C42	C43	C44	C45	C46
Material density	t/m ³	1,8	1,8	1,6	1,6	1,6
Bucket weight	kg	2.365	2.445	2.335	2.495	2.570
Static tipping load, straight	kg	20.705	20.465	20.735	20.520	20.295
Static tipping load, 37° articulated	kg	18.325	18.100	18.365	18.145	17.935
Break-out force hydraulic	kN	240	227	228	228	217
Lifting capability hydr. at ground level	kN	263	261	262	262	260
Operating weight (without add. counterw.)	kg	25.400	25.480	25.370	25.530	25.605
Turning radius at corner of tyres	mm	7000	7000	7.000	7000	7000
Turning radius at bucket edge	mm	7760	7715	7700	7780	7735
a Reach at 45°	mm	1.542	1.389	1.410	1.595	1.440
b Dump height at 45°	mm	3.032	3.143	3.165	2.980	3.090
c Hinge pin height	mm	4.483	4.483	4.485	4.485	4.485
d Height top edge of bucket	mm	6.110	6.110	6.140	6.140	6.140
e Digging depth	mm	130	160	130	130	160
f Max. loading height at 45°	mm	4.160	4.160	4.160	4.160	4.160
A Overall length, bucket grounded	mm	9.420	9.420	9.235	9.495	9.330
B Wheelbase	mm	3.450	3.450	3.450	3.450	3.450
C Bucket width	mm	3.165	3.170	3.160	3.165	3.170
D Width over tyres	mm	2.975	2.975	2.975	2.975	2.975
E Track width	mm	2.300	2.300	2.300	2.300	2.300
F Ground clearance	mm	500	500	500	500	500
H Overall height	mm	3.465	3.465	3.465	3.465	3.465

All measurements with tyres 26.5 R25.

Details of dumping heights and reach to cutting edge or bolt-on cutting edge (BOC) or teeth



CHANGE IN DATA CAUSED BY:

	Without add. counterweight (rear)	Tyres 26.5 R25 XLD D1A L4	Tyres 26.5 R25 XMINE D2 L5
Operating weight	- 400 kg	+ 392 kg	+ 1.124 kg
Static tipping load, straight	- 1.020 kg	+ 280 kg	+ 795 kg
Static tipping load, 37° articulated	- 890 kg	+ 250 kg	+ 720 kg
Overall length, bucket grounded	- 165 mm	-	-
Reach at 45°	-	- 35 mm	- 29 mm
Dump height at 45°	-	+ 35 mm	+ 45 mm
Width over tyres	-	+ 17 mm	+ 45 mm
Overall height	-	+ 35 mm	+ 45 mm

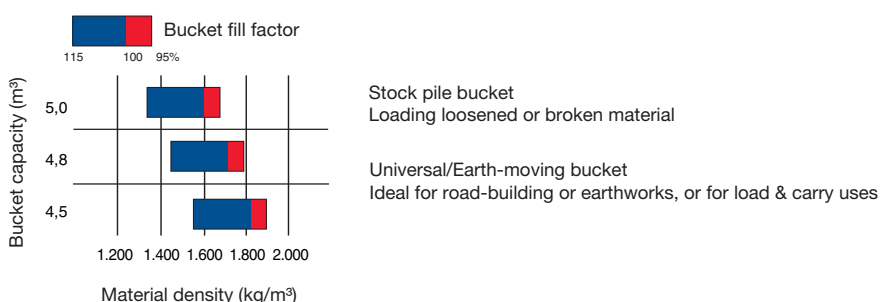

TYPICAL MATERIAL DENSITY – LOOSE (IN kg/m³)

Basalt	1.960
Bauxite, Kaolin	1.420
Earth, dry, ex store	1.510
Earth, wet, excavated	1.600
Gypsum, broken	1.810
Gypsum, crushed	1.600
Granite, broken	1.660
Limestone, broken	1.540
Limestone, crushed	1.540
Gravel, unscreened	1.930
Gravel, dry	1.510
Gravel, dry, 6-50 mm	1.690
Gravel, wet, 6-50 mm	2.020
Sand, dry, loose	1.420
Sand, damp	1.690
Sand, wet	1.840
Sand and clay, loose	1.600
Sand and gravel, dry	1.720
Sandstone	1.510
Slate	1.250
Slag, broken	1.750
Stone, crushed	1.600
Clay, natural	1.660
Clay, dry	1.480
Clay, wet	1.660
Clay and gravel, dry	1.420
Clay and gravel, wet	1.540

Stock pile with raised bottom			Universal		
w/o teeth	w. teeth	with BOC	w/o teeth	w. teeth	with BOC
4,9	4,9	5,0	4,65	4,65	4,80
C21	C22	C23	C15	C16	C17
1,6	1,6	1,6	1,8	1,7	1,7
2.135	2.295	2.270	2.105	2.260	2.345
20.835	20.620	20.395	21.125	20.915	20.670
18.465	18.245	18.035	18.740	18.530	18.305
228	228	217	244	244	232
262	262	260	263	263	263
25.370	25.530	25.605	25.140	25.295	25.380
7.000	7000	7000	7.000	7000	7000
7700	7780	7735	7.675	7.750	7.710
1.410	1.595	1.440	1.360	1.530	1.375
3.165	2.980	3.090	3.230	3.045	3.160
4.485	4.485	4.485	4.485	4.485	4.485
6.140	6.140	6.140	6.170	6.170	6.170
130	130	160	130	130	160
4.160	4.160	4.160	4.160	4.160	4.160
9.235	9.495	9.330	9.140	9.400	9.235
3.450	3.450	3.450	3.450	3.450	3.450
3.160	3.165	3.170	3.160	3.165	3.170
2.975	2.975	2.975	2.975	2.975	2.975
2.300	2.300	2.300	2.300	2.300	2.300
500	500	500	500	500	500
3.465	3.465	3.465	3.465	3.465	3.465

Wheel Loader

WA480-6

Standard and Optional Equipment

ENGINE

Komatsu SAA6D125E-5 turbocharged common rail direct injection diesel engine	●
EU Stage IIIA/EPA Tier III compliant	
Fuel filter with water separator	●
Engine cooling fluid corrosion resistor	●
Alternator 50 A/24 V	●
Starter motor 11 kW/24 V	●
Batteries 2 × 180 Ah/2 × 12 V	●

CHASSIS AND TYRES

Heavy-duty axles	●
Front fenders	●
Limited-slip differential (LSD) front and rear	○
Tyres 26.5 R25 L2, L3, L5	○
Full rear fenders	○

SAFETY EQUIPMENT

Emergency steering system	●
Horn	●
Vandalism protection	●
Back-up alarm	●
Battery main switch	●
Handrails on left/right	●
Front screen protective grid	○
Beacon light	○
Electronic anti-theft lock	○
Roof rail	○
Rear view camera system	○
Additional convex rear view mirror	○
Optical back-up alarm (strobe light)	○

LIGHTING SYSTEM

2 halogen main headlights	●
2 spotlights at front and rear	●
Reversing light	●
Additional lights front and rear	○
Xenon working lights	○
Step light	○

CABIN

Spacious double door driver's cab to DIN/ISO	●
ROPS/FOPS frame according to SAE	●
Air-suspended, heated seat	●
Air conditioner	●
CD radio	●
Hot and cool box	●
All-round tinted glazing	●
Front laminated glass	●
Heated rear window	●
Rear window wiper	●
Sun visor	●
Seat belt (EU standard)	●
Adjustable steering column	●
12 V power supply	○
Fire extinguisher	○
Sun roller blind	○
Automatic climate control system	○

TRANSMISSION AND BRAKES

Electronically controlled ECMV automatic transmission with mode selector and variable transmission cut-off	●
Working mode selection system	●
Large-capacity torque converter	●
Fully hydraulic brake system	●
Torque converter lock-up	○
Joystick steering with integrated F/R transmission function, 2-stage	○

HYDRAULIC SYSTEM

2-spool main control valve	●
PPC fingertip control, two levers	●
Automatic return-to-dig	●
3-spool main control valve	○
PPC control, 1-lever (Multi-function lever) with integrated F/R transmission function	○
Electronic 2-lever control (EPC) including:	
- Bucket stop modulation	○
- Boom stop pre-setting	
- Semiautomatic dig function	
Biodegradable oil for hydraulic system	○

SERVICE AND MAINTENANCE

Hydrostat-driven radiator fan with automatic reversing function	●
EMMS (Equipment Management Monitoring System) with self-diagnostic function and maintenance display	●
KOMTRAX™ - Komatsu satellite monitoring system	●
Tool-set	●
Automatic central lubrication	●
Filling tool for central lubrication system	○
Turbo II air pre-cleaner, cyclone type	○

OTHER EQUIPMENT

Counterweight	●
Electronically controlled load stabilizer (ECSS)	●
Add. counterweight 400 kg	●
Special custom colour	○
Anti-corrosion specification	○
Waste-handler specification	○
Cold area kit (engine and cab pre-heating)	○

ATTACHMENTS

Hydraulic quick-coupler	○
Universal buckets	○
Earthmoving buckets	○
Stock pile buckets	○
High-dump buckets	○
Log grapples	○
Fork carrier and tines	○
Waste handling buckets	○
Light material buckets	○

Further equipment on request

The WA480-6 is equipped in accordance with the safety regulations of the machinery guidelines 89/392 EWG ff and EN474.

- standard equipment
- optional equipment

Your Komatsu partner:

KOMATSU

**Komatsu Europe
International NV**
Mechelsesteenweg 586
B-1800 VILVOORDE (BELGIUM)
Tel. +32-2-255 24 11
Fax +32-2-252 19 81
www.komatsu.eu

VESS003100 04/2009

Materials and specifications are subject to change without notice.
KOMATSU is a trademark of Komatsu Ltd. Japan.