

KOMATSU

WA480-8

EU Stage V Engine

WHEEL LOADER



WA480

ENGINE POWER

224 kW / 300 HP @ 2.000 rpm

OPERATING WEIGHT

26.315 - 27.535 kg

BUCKET CAPACITY

4,8 - 5,5 m³

Walk-Around

W/A 480-8



ENGINE POWER

224 kW / 300 HP @ 2.000 rpm

OPERATING WEIGHT

26.315 - 27.535 kg

BUCKET CAPACITY

4,8 - 5,5 m³



INCREASED FUEL EFFICIENCY AND ENVIRONMENTAL PERFORMANCE

Powerful and Environmentally Friendly

- EU Stage V engine
- Komatsu SmartLoader Logic
- E-Light engine mode
- Large-capacity torque converter with standard lock-up
- Adjustable idle shutdown

First-Class Comfort

- New, air-suspended operator seat with integrated EPC lever console
- Large multifunctional monitor
- Low-noise design
- Rear-view camera system
- Komatsu short lever steering (K-SLS) (option)

Maximised Efficiency

- High efficiency buckets
- Superior dumping height and reach
- Wide tread and long wheelbase

State-of-the-Art Controls

- Automatic digging system
- Electronic Pilot Control (EPC) standard
- Intelligent gas pedal

Easy Maintenance

- Wide-core radiator with auto reverse fan
- Factory fitted automatic lubrication system
- Improved gull-wing type engine doors

KOMTRAX

- Komatsu Wireless Monitoring System
- 3G mobile communications
- Integrated communication antenna
- Increased operational data and fuel savings



A maintenance program
for Komatsu customers

Powerful and Environmentally Friendly



Komatsu SmartLoader Logic

The WA480-8 provides Komatsu SmartLoader Logic, a fully automatic engine control system. Without interfering with normal operations, this technology acquires data from various sensors in the vehicle and delivers optimal engine torque for each work phase. It limits torque during less demanding operations and reduces fuel usage without decreasing production.

Large-capacity torque converter with standard lock-up

With its large-capacity torque converter, the completely redesigned Komatsu drive train offers optimum efficiency and an unparalleled rimpull-to-weight ratio. By delivering high rimpull at low speeds, it makes child's play of heavy jobs like penetration of dense material such as aggregate. This means higher productivity in V-Shape loading, even in confined spaces.

New E-Light mode

Switched on by default, the new E-Light mode prioritizes a lower fuel consumption. For increased fuel efficiency, the engine matches power to the current working phase. Electronically controlled hydraulic pumps for the work equipment and steering system prevent wasted hydraulic flow and deliver the exact amount of oil required for all machine movements.

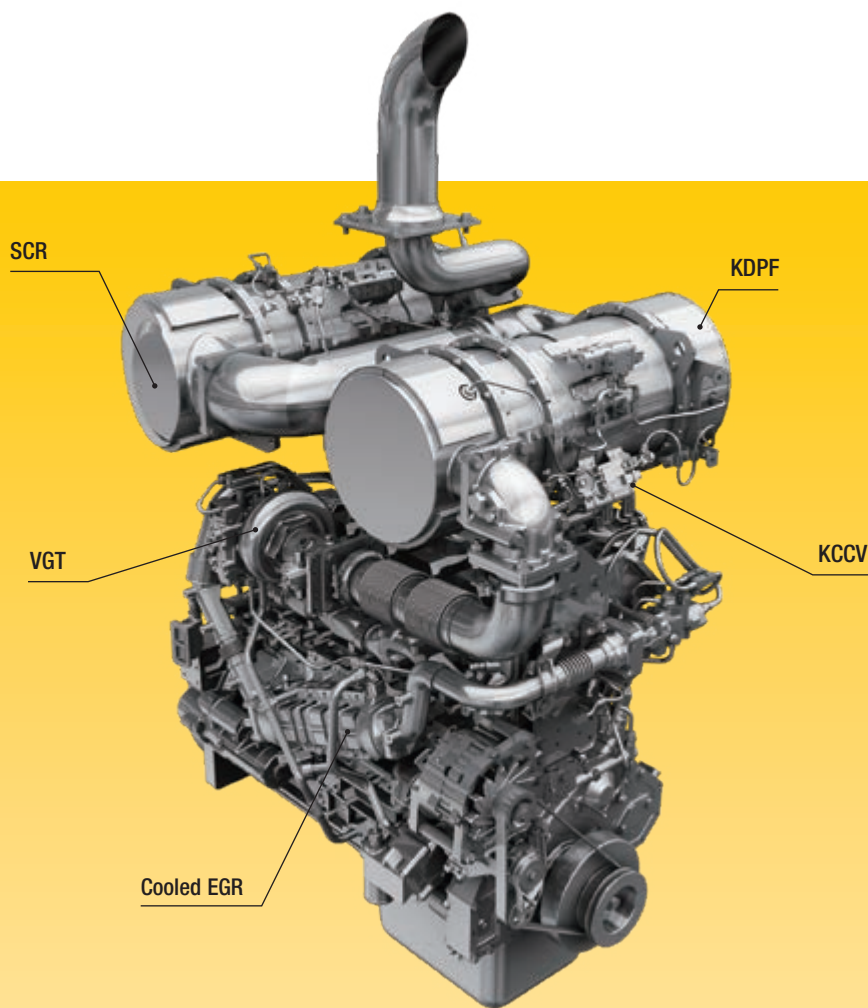

Komatsu EU Stage V

The Komatsu EU Stage V engine is productive, dependable and efficient. With ultra-low emissions, it provides a lower environmental impact and a superior performance to help reduce operating costs and lets the operator work in complete peace of mind.

Heavy-duty aftertreatment

The aftertreatment system combines a Komatsu Diesel Particulate Filter (KDPF) and Selective Catalytic Reduction (SCR). The SCR injects the correct amount of AdBlue® into the system at the proper rate to break down NOx into water (H₂O) and non-toxic nitrogen gas (N₂). NOx emissions are reduced by 80% vs. EU Stage IIIB engines.

Exhaust Gas Recirculation (EGR)

Cooled EGR is a technology well-proven in current Komatsu engines. The increased capacity of the EGR cooler now ensures very low NOx emissions and a better engine performance.

Komatsu Closed Crankcase Ventilation (KCCV)

Crankcase emissions (blow-by gas) are passed through a CCV filter. The oil mist trapped in the filter is returned back to the crankcase while the filtered gas is returned to the air intake.

High-Pressure Common Rail (HPCR)

To achieve complete fuel burn and lower exhaust emissions, the heavy-duty High-Pressure Common Rail fuel injection system is computer controlled to deliver a precise quantity of pressurised fuel into the redesigned engine combustion chamber by multiple injections.

Variable Geometry Turbo (VGT)

The VGT provides optimal airflow to the engine combustion chamber under all speed and load conditions. Exhaust gas is cleaner, fuel economy is improved while machine power and performance are maintained.

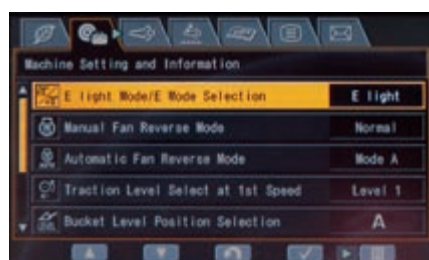
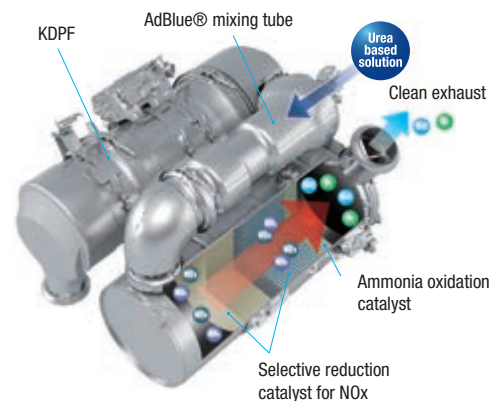

New E-Light engine mode enables increased fuel savings compared to current Economy mode



Adjustable idle shutdown automatically turns off the engine after it idles for a set period of time



Eco-gauge and an Eco guidance with active recommendations help maximising fuel savings

Maximised Efficiency

Faster Load & Carry

The sequential torque converter lock-up system delivers unbeatable productivity and fuel efficiency in Load & Carry and short distance transport applications. The operator can engage the system from 2nd to 4th gear. It noticeably increases travel speed, particularly when going uphill, thanks to the larger tractive force. It also significantly reduces fuel consumption by eliminating converter losses.

Superior dumping height and reach

The long lifting frame allows an enormous dumping height of 3.045 m and a reach of 1.475 m that is just as impressive (with a 5,0 m³ bucket, measured to the cutting edge). With this working range, loading high feeders or trucks becomes easy and fast.



New high efficiency buckets

Soil slips easily from the redesigned bucket, and digging work is more efficient. Operations are quicker and productivity improved, especially in combination with the new auto digging system.

Precision control

Komatsu's CLSS hydraulics enables extremely precise control of the work equipment, and ensures that the bucket, boom and hydraulically driven attachments can all move smoothly at the same time. The WA480-8 also features variable-displacement pumps on both the hydraulic and steering systems. These pumps deliver the exact amount of oil required, dramatically improving fuel efficiency.

Factory installed RDS weighing system (option)

The RDS Loadmaster alpha 100 is an advanced and trade-approved on-board weighing system specifically designed to operate in the fastest loading environments and toughest conditions. The Loadmaster compensates for uneven, sloped ground and restricted loading areas to reduce your cycle times and maximise tonnes-per-hour performance. The RDS Loadmaster alpha 100 factory installation enhances the assembly's accuracy and the quality of the system.





First-Class Comfort

Increased comfort

In the wide Komatsu SpaceCab™, a standard air-suspended high-back seat, heated for improved comfort and with fully adjustable armrests, is the centre of a comfortable and low-fatigue working environment. High visibility and ergonomic controls help to maximise the operator's productivity.

Perfect operator convenience

In addition to the standard radio and speakers, and two 12-volt power ports, the WA480-8 cab has an auxiliary input for external music devices. Proportional controls are fitted as standard for safe and precise operation of attachments. The cab features large trays and storage boxes for tools and manuals and a hot and cool box.

New automatic digging system

The new automatic digging system actuates the bucket tilt and lifting operations by detecting the sensing pressure applied to the work equipment. The system adapts to different types of material with no human intervention required. Operator fatigue is greatly reduced and ideal load capacity ensured.



State-of-the-Art Controls

New, fully air suspended operator station

The wide spacious cab features a new, fully air-suspended operator seat that includes the side consoles mounted together with a high back, fully adjustable, standard heated seat for improved comfort. A seat ventilation is optionally available to maximise comfort.

“By Wire” operating

The Electronic Pilot Control (EPC) lever console is integrated with the seat and can be easily adjusted to suit any operator. The short levers are fingertip controlled for precise and fatigue-free operating, with a no-vibration modulating function for slowing and stopping a lowering bucket. The upper and lower boom cut-out position can be pre-set with a switch.

Intelligent gas pedal

To reduce fuel usage, Komatsu's innovative thrust-sensing gas pedal automatically helps you match the timing of gear shifts to the load. In heavy-duty work, requiring high rimpull and maximum acceleration, we tend to press heavily on the gas pedal. The WA480-8 anticipates this and shifts up gears as late as possible. In light-duty work, where fuel consumption is a major factor, the operator will intuitively press the gas pedal lightly. Again, the machine anticipates this – and shifts up gears as early as possible to achieve highest fuel efficiency.

Rear view camera

A standard fitment camera gives an exceptionally clear view of the rear work zone on the wide-screen colour monitor panel. The low profile camera is adjustable and integrated into the engine hood's shape.

EPC-multi-function lever (option)

The EPC-multi-function lever with an integrated forward/reverse switch allows the simplest and most comfortable operation of the equipment. With one hand the driver can simultaneously control the attachment and switch between forward and reverse. The multi-function lever is the perfect choice for earth moving jobs.

Komatsu Short Lever Steering (K-SLS) (option)

The new finger-type joystick steering allows more accurate steering by the operator who can now sit relaxed in the new air-suspended and fully adjustable seat to control the machine with no big effort needed for frequent steering. Less fatigue and work in a perfectly adapted operating position will improve concentration and the quality and efficiency of the work.



Komatsu short lever steering (K-SLS) (option)



Hot and cool box



EPC-Multifunction lever (option)

Information & Communication Technology



Lower operating costs

Komatsu ICT contributes to the reduction of operating costs by assisting to comfortably and efficiently manage operations. It raises the level of customer satisfaction and the competitive edge of our products.

Large TFT colour monitor

A large user-friendly colour monitor enables safe, accurate and smooth work. Multilingual and with all essential information available at a glance, it features simple and easy-to-operate switches and multifunction keys that provide fingertip access to a wide range of functions and operating information.

Eco guidance

The monitor panel displays instant guidance messages to help promote energy saving, and the Eco-gauge indicates the actual fuel consumption: keep the Eco-gauge in the green zone for better fuel efficiency. To further improve savings, logs can be consulted for operations, Eco guidance and fuel consumption. The information is available in KOMTRAX and can be used for operator trainings and jobsite optimisation.



Information at a glance: basic dashboard LCD monitor



A multifunction monitor displays and controls a wealth of operational and maintenance information

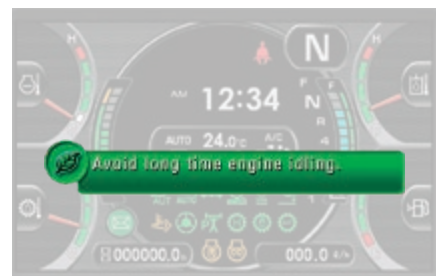

Eco guidance supports energy saving in real time (e.g. avoid long time engine idling)

KOMTRAX

The way to higher productivity

KOMTRAX uses the latest wireless monitoring technology. Compatible on PC, smartphone or tablet, it delivers insightful and cost saving information about your fleet and equipment, and offers a wealth of information to facilitate peak machine performance. By creating a tightly integrated web of support it allows proactive and preventive maintenance and helps to efficiently run a business.



Knowledge

You get quick answers to basic and critical questions about your machines – what they're doing, when they did it, where they're located, how they can be used more efficiently and when they need to be serviced. Performance data is relayed by wireless communication technology (satellite, GPRS or 3G depending on model) from the machine to a computer and to the local Komatsu distributor – who's readily available for expert analysis and feedback.

Power

The detailed information that KOMTRAX puts at your fingertips 24 hours a day, 7 days a week gives the power to make better daily and long-term strategic decisions – at no extra cost. Problems can be anticipated, maintenance schedules customised, downtime minimised and machines kept where they belong: working on the jobsite.

Convenience

KOMTRAX enables convenient fleet management on the web, wherever you are. Data is analysed and packaged specifically for effortless and intuitive viewing in maps, lists, graphs and charts. You can foresee eventual maintenance issues and required spare parts, and troubleshoot a problem before Komatsu technicians arrive on site.



Easy Maintenance



Easy access to service points

For easy and safe opening the gull-wing doors are supported by gas springs. The large doors give a convenient access from ground level to all daily service points. With long service intervals and filters collected in a centralised arrangement, machine downtime is reduced to a minimum.

Komatsu CARE™

Komatsu CARE™ is a maintenance program that comes as standard with your new Komatsu machine. It covers factory-scheduled maintenance, performed with Komatsu Genuine parts by Komatsu-trained technicians. Depending on your machine's engine, it also offers extended coverage of the Komatsu Diesel Particulate Filter (KDPF) or the Komatsu Diesel Oxidation Catalyst (KDOC), and of the Selective Catalytic Reduction (SCR). Please contact your local Komatsu distributor for terms and conditions.



Wide-core radiator with auto reverse fan

A wide-core radiator prevents clogging even when working in a dusty environment. To minimize manual cleaning, a reversible fan blows dust out, automatically or on demand. The "automatic reverse" function allows to set the cleaning length and the time between cleaning to adjust perfectly to the working conditions.

Equipment Management and Monitoring System (EMMS)

The large high resolution monitor panel displays various machine information and allows for multiple settings. The "Operation Records" menu shows records of the average fuel consumption, idling hours, and other features. Abnormality codes are clearly displayed and stored to alert you and simplify troubleshooting. The monitor also provides for advanced monitoring of the system parameters through the service mode to aid in troubleshooting and reduce downtime.



AdBlue® tank

The AdBlue® tank is located on the right hand side of the machine behind a ladder for easy access.

Diesel particulate filter regeneration

No interruption or extension of daily work is required to regenerate the diesel particulate filter system. Due to its superior Komatsu technology, KDPF regeneration takes place automatically, at any time.





Basic maintenance screen



Aftertreatment device regeneration screen for the KDPF



AdBlue® level gauge and refill guidance



Tailored Solutions



Working gear division

Komatsu wheel loaders can combine with a wide range of genuine Komatsu attachments to provide the perfect solution for any industry sector. For special applications our “Working Gear” division offers purpose-built machines and attachments. Tailor-made solutions allow high performance and outstanding reliability even under toughest conditions.

Waste handling

We configure our wheel loaders to work in the difficult environment of waste handling job sites. Along with heavy duty attachments, we offer solutions to protect your machine against damage.

Timber industry

A wide range of options specifically developed for the timber industry are available: wood chip buckets, cameras, as well as various protections and pre-filters.

WA480-8

Quality You Can Rely On

Designed and built by Komatsu

The engine, hydraulics, power train, front and rear axles are original Komatsu components. All components, right down to the smallest screw, are subject to the highest quality standards, and are fully coordinated with one another for maximum efficiency and reliability.

Heavy-duty axles

The heavy-duty axles allow exceptional service life even under the toughest working conditions. The optional limited slip differentials are most suitable for soft and slippery ground like sand or wet soil.

Robust torsion-resistant main frame

The frame design, with hinge points placed far apart, guarantees high stability for the overall design and reduces bearing stress in the torsional ranges.

Axle oil cooling system

Overheated axle oil can cause a decline in productivity due to required machine cool downs. To maintain high efficiency in Load & Carry applications, the Komatsu WA480-8 is equipped as standard with an axle oil cooling system that keeps oil at a constant temperature even over long hauling distances.

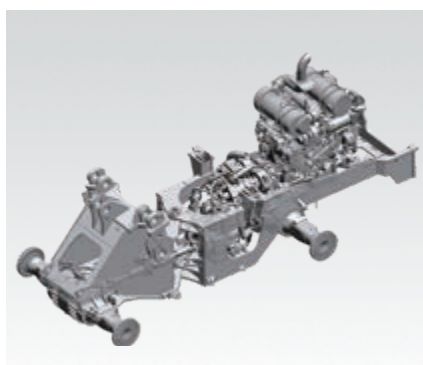

Robust torsion-resistant main frame

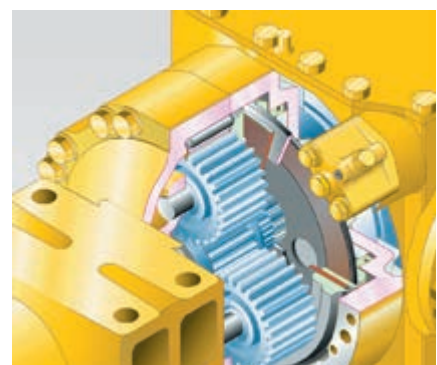

Wet multi-disc service brake

Aggregate Handling Specification

W/A 480-8

Aggregate handling specification (option)

With higher payloads and bucket capacities, this specification reduces the number of passes needed to load a truck. It sets new standards for productivity, fuel efficiency and comfort. The optimised Z-bar loader linkage, together with high-efficiency buckets, delivers improved payloads and bucket longevity. Enhancements in the frame structure and the heavy-duty axles, combined with the axles' oil cooling system and a heavier rear counterweight, provide the necessary stability and durability of this version, which is optimised for material handling.



Buckets and Attachments

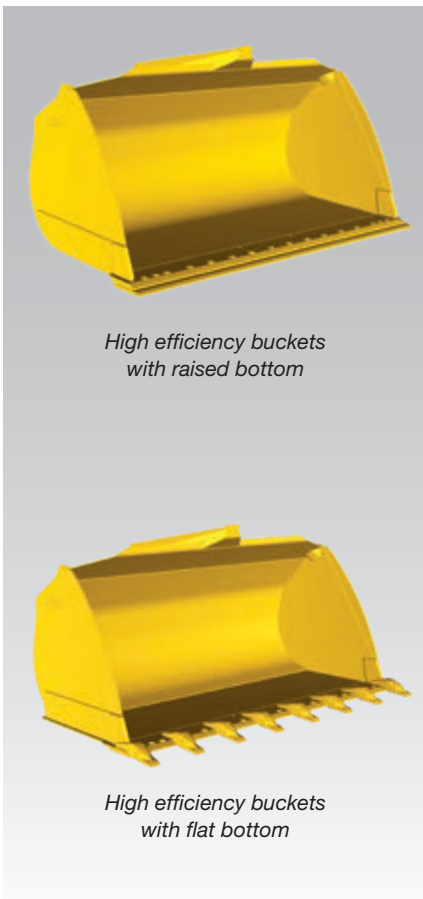

High efficiency buckets with raised bottom

High efficiency buckets with flat bottom

New high efficiency bucket range

The new Komatsu buckets enable easier bucket fill and significantly higher fill factors, contributing to more efficiency and less fuel consumption. They feature a longer bottom allowing for more content, a wider opening for an easier fill and a new rear shape that enables material to flow easily into the bucket. Their rounded sides give them a higher fill factor, and an integrated spill guard protects the bucket linkage. Flush screws (with BOC) reduce resistance when filling and keep material from clogging when dumping.

High dump buckets

For maximum dumping heights with light materials like coal or woodchips. The dump cylinders are located either inside or outside the bucket.

Mulch grab buckets

Perfectly suited for picking up bulky and compressible materials like gardening or plastic waste, etc. Without the side plates, this bucket can be used also as a grapple.

Hydraulic quick coupler

The WA480-8 can change attachments in a matter of seconds with the HD hydraulic quick-coupler, available as optional equipment.

Specifications

WA480-8E0

ENGINE

Model	Komatsu SAA6D125E-7
Type	Common rail direct injection, water-cooled, emissionised, turbocharged, after-cooled diesel
Engine power	
at rated engine speed	2.000 rpm
ISO 14396	224 kW / 300 HP
ISO 9249 (net engine power)	223 kW / 299 HP
ISO 9249 (max. engine power)	235 kW / 315 HP
at engine speed	1.700 rpm
Max. torque / engine speed	1.390 Nm / 1.400 rpm
No. of cylinders	6
Bore x stroke	125 x 150 mm
Displacement	11,04 l
Fan drive type	Hydraulic
Alternator	90 A / 24 V
Starter motor	7,5 kW / 24 V
Filter	Main-flow filter with water separator
Air-filter type	Dry-air filter with automatic dust emission and preliminary purification including a dust display
Fuel	Diesel fuel, conforming to EN590 Class 2/ Grade D. Paraffinic fuel capability (HVO, GTL, BTL), conforming to EN 15940:2016

TRANSMISSION

Type	Automatic powershift transmission
Torque converter	One-stage, one-phase, 3-element, with lock-up clutch

SPEEDS IN KM/H (WITH 26.5 R25 TYRES)

Gear	1.	2.	3.	4.
Forward	7,6	13,2	22,7	36,2
with torque converter lock-up	-	13,5	23,6	39,0
Reverse	7,9	13,5	23,5	37,3
with torque converter lock-up	-	13,8	24,3	39,0

CHASSIS AND TYRES

System	4-wheel drive
Front axle	Komatsu HD axle, semi-floating (LSD-differential optional)
Rear axle	Komatsu HD axle, semi-floating, 26° swing angle (LSD-differential optional)
Differential	Straight bevel gear pair
Final drive	Planetary gear in an oil bath
Tyres	26.5 R25

SERVICE REFILL CAPACITIES

Fuel tank	380 l
Engine oil	38 l
Hydraulic system	173 l
Cooling system	81 l
Front axle	60 l
Rear axle	60 l
Torque converter and transmission	65 l
AdBlue® tank	36 l

BRAKES

Operating brakes	Hydraulically actuated, wet multi-disc brakes on all wheels
Parking brake	Wet multi-disc
Emergency brake	Uses the parking brake

HYDRAULIC SYSTEM

Type	Komatsu CLSS (Closed Centre Load Sensing System)
Hydraulic pump	Variable piston pump
Working pressure	350 kg/cm ²
Maximum pump flow	260 l/min
No. of hydraulic/bucket cylinders	2/1
Type	Double-action
Bore diameter x stroke	
Boom cylinder	140 x 881 mm
Bucket cylinder	180 x 572 mm
Hydraulic cycle with rated load bucket filling	
Raise time	5,9 s
Lowering time (empty)	3,5 s
Dumping time	1,9 s

STEERING SYSTEM

System	Articulated frame steering
Type	Completely hydraulic power steering
Steering angle to either side	40°
Steering pump	Variable piston pump
Working pressure	250 kg/cm ²
Pumping capacity	195 l/min
No. of steering cylinders	2
Type	Double-action
Bore diameter x stroke	90 x 441 mm
Smallest turn (outer edge of the tyre 26.5 R25)	6.970 mm

CABIN

Two-door SpaceCab™ in conformity with ISO 3471 with ROPS (roll over protective structure) in conformity with SAE J1040c and FOPS (falling object protective structure) in conformity with ISO 3449. The air-conditioned pressurised cabin is mounted upon hydrobearings and is noise dampened.

ENVIRONMENT

Engine emissions	Fully complies with EU Stage V exhaust emission regulations
Noise levels	
LwA external	108 dB(A) (2000/14/EC Stage II)
LpA operator ear	71 dB(A) (ISO 6396 dynamic test)
Vibration levels (EN 12096:1997)	
Hand/arm	≤ 2,5 m/s ² (uncertainty K = 0,66 m/s ²)
Body	≤ 0,5 m/s ² (uncertainty K = 0,21 m/s ²)
Contains fluorinated greenhouse gas HFC-134a (GWP 1430). Quantity of gas 1,1 kg, CO ₂ equivalent 1,57 t.	

Dimensions & Performance Figures

MEASUREMENTS AND WORKING SPECIFICATIONS

Bucket type		Bucket with flat bottom			
		w. teeth	w. BOC	w. teeth	w. BOC
Bucket capacity (heaped, ISO 7546)	m ³	4,8	5,0	5,0	5,3
Sales code		C66	C67	C62	C63
Material density	t/m ³	1,65	1,55	1,55	1,45
Bucket weight	kg	2.440	2.505	2.520	2.585
Static tipping load, straight	kg	20.165	19.945	19.995	19.740
Static tipping load, 40° articulated	kg	17.500	17.300	17.305	17.105
Break-out force hydraulic	kN	216	205	204	194
Lifting capability hydr. at ground level	kN	221	218	218	216
Operating weight	kg	26.315	26.380	26.400	26.465
Turning radius at corner of tyres	mm	6.970	6.970	6.970	6.970
Turning radius at bucket edge	mm	7.815	7.760	7.840	7.785
a Reach at 45°	mm	1.630	1.475	1.680	1.540
b Dumping height at 45°	mm	2.915	3.045	2.860	2.980
c Hinge pin height	mm	4.485	4.485	4.485	4.485
d Height top edge of bucket	mm	6.245	6.245	6.315	6.315
e Digging depth	mm	140	170	140	170
f Max. loading height at 45°	mm	4.145	4.145	4.145	4.145
A Overall length, bucket grounded	mm	9.600	9.420	9.675	9.510
B Wheel base	mm	3.450	3.450	3.450	3.450
C Bucket width	mm	3.170	3.170	3.170	3.170
D Width over tyres	mm	3.010	3.010	3.010	3.010
E Track width	mm	2.300	2.300	2.300	2.300
F Ground clearance	mm	505	505	505	505
H Overall height	mm	3.575	3.575	3.575	3.575

All measurements with tyres 26.5 R25 (XHA) and additional counterweight A15.
 Details of dumping heights and reach to cutting edge or bolt-on cutting edge (BOC) or teeth.

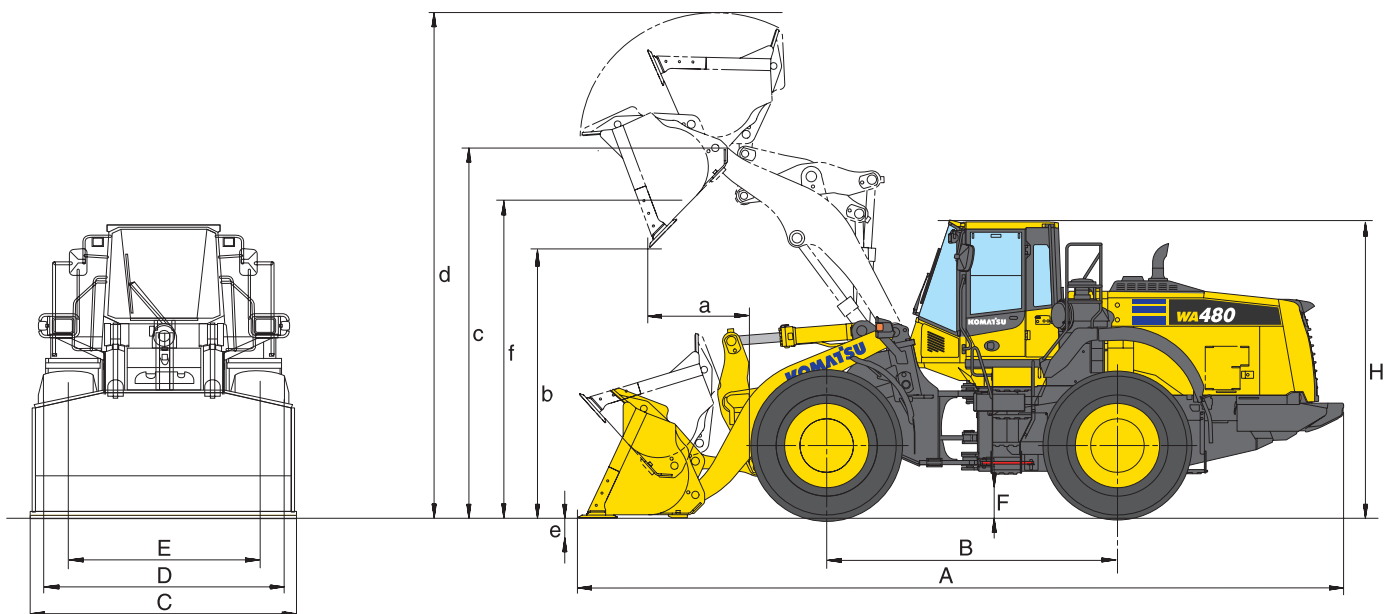

WA480-8

Bucket with raised bottom				Change in data caused by:	
w. teeth	w. BOC	w. teeth	w. BOC	Tyres L4	Tyres L5
4,8	5,0	5,0	5,3		
C86	C87	C76	C77		
1,70	1,6	1,55	1,45		
2400	2455	2.505	2.565		
20.255	20.070	20.005	19.800	+ 280	+ 720
17.590	17.414	17.155	17.355	+ 245	+ 635
216	205	204	194		
221	220	218	216		
26.275	26.330	26.315	26.380	+ 400	+ 1.040
6.970	6.970	6.970	6.970		
7.815	7.760	7.840	7.785		
1.630	1.475	1.680	1.540	- 10	- 35
2.915	3.045	2.860	2.980	+ 15	+ 45
4.485	4.485	4.485	4.485		
6.245	6.245	6.315	6.315		
140	170	140	170		
4.145	4.145	4.135	4.135		
9.600	9.420	9.675	9.510		
3.450	3.450	3.450	3.450		
3.170	3.170	3.170	3.170		
2.975	2.975	3.010	3.010	+ 20	+ 35
2.300	2.300	2.300	2.300		
505	505	505	505		
3.575	3.575	3.575	3.575	+ 15	+ 45

TYPICAL MATERIAL DENSITY – LOOSE (in kg/m³)

Basalt	1.960
Bauxite, Kaolin	1.420
Earth, dry, ex store	1.510
Earth, wet, excavated	1.600
Gypsum, broken	1.810
Gypsum, crushed	1.600
Granite, broken	1.660
Limestone, broken	1.540
Limestone, crushed	1.540
Gravel, unscreened	1.930
Gravel, dry	1.510
Gravel, dry, 6-50 mm	1.690
Gravel, wet, 6-50 mm	2.020
Sand, dry, loose	1.420
Sand, damp	1.690
Sand, wet	1.840
Sand and clay, loose	1.600
Sand and gravel, dry	1.720
Sandstone	1.510
Slate	1.250
Slag, broken	1.750
Stone, crushed	1.600
Clay, natural	1.660
Clay, dry	1.480
Clay, wet	1.660
Clay and gravel, dry	1.420
Clay and gravel, wet	1.540

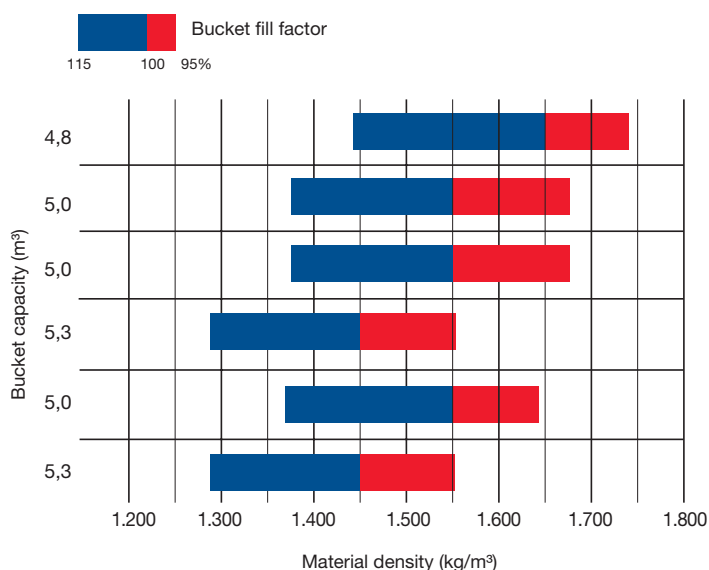

Dimensions & Performance Figures

MEASUREMENTS AND WORKING SPECIFICATIONS

Bucket type		Bucket with flat bottom			Bucket with raised bottom		
		w. teeth	w. BOC	w/o teeth	w. BOC	w/o teeth	w. BOC
Bucket capacity (heaped, ISO 7546)	m ³	4,8	5,0	5,0	5,3	4,8	5,0
Bucket mount (direct/quick-coupler)		direct	direct	direct	direct	direct	direct
Sales code		C66	C67	C62	C63	C86	C87
Material density	t/m ³	1,85	1,75	1,75	1,65	1,85	1,75
Bucket weight	kg	2.430	2.490	2.515	2.570	2.400	2.455
Static tipping load, straight	kg	21.020	20.805	20.805	20.600	21.105	20.905
Static tipping load, 40° articulated	kg	18.105	17.915	17.910	17.720	18.190	18.010
Break-out force hydraulic	kN	216	205	204	194	216	205
Lifting capability hydr. at ground level	kN	221	219	218	216	221	220
Operating weight	kg	26.805	26.865	26.890	26.945	26.775	26.830
Turning radius at corner of tyres	mm	6.970	6.970	6.970	6.970	6.970	6.970
Turning radius at bucket edge	mm	7.810	7.760	7.840	7.785	7.810	7.760
a Reach at 45°	mm	1.630	1.475	1.695	1.540	1.630	1.475
b Dumping height at 45°	mm	2.915	3.045	2.850	2.980	2.915	3.045
c Hinge pin height	mm	4.485	4.485	4.485	4.485	4.485	4.485
d Height top edge of bucket	mm	6.245	6.245	6.315	6.315	6.245	6.245
e Digging depth	mm	140	170	140	170	140	170
f Max. loading height at 45°	mm	4.145	4.145	4.145	4.145	4.145	4.145
A Overall length, bucket grounded	mm	9.600	9.420	9.690	9.510	9.600	9.420
B Wheel base	mm	3.450	3.450	3.450	3.450	3.450	3.450
C Bucket width	mm	3.170	3.170	3.170	3.170	3.170	3.170
D Width over tyres	mm	3.010	3.010	3.010	3.010	3.010	3.010
E Track width	mm	2.300	2.300	2.300	2.300	2.300	2.300
F Ground clearance	mm	505	505	505	505	505	505
H Overall height	mm	3.575	3.575	3.575	3.575	3.575	3.575

All measurements with tyres 26.5 R25 (XHA) and additional counterweight A19.
 Details of dumping heights and reach to cutting edge or bolt-on cutting edge (BOC) or teeth.

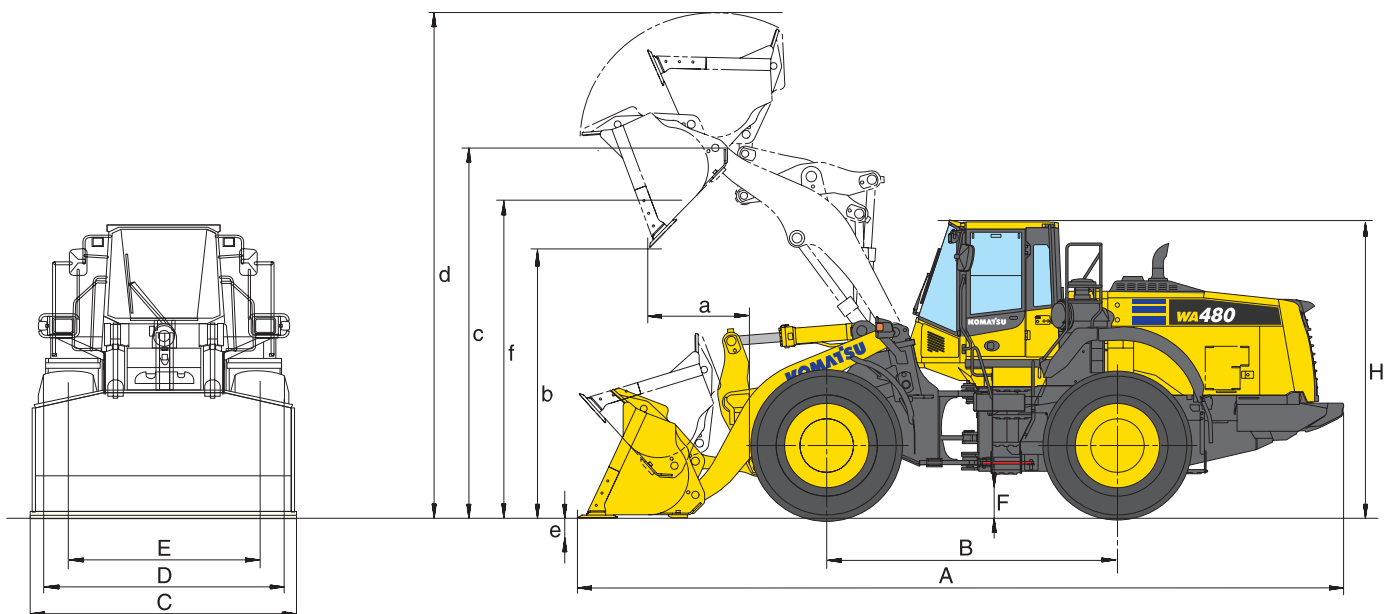

Aggregate Handling Specification

Bucket with raised bottom				Bucket with raised bottom						Change in data caused by:
w. teeth	w. BOC	w. teeth	w. BOC	w. teeth	w. BOC	w. teeth + segments	w. teeth	w. BOC	w. teeth + segments	Tyres L5
5,0	5,3	5,2	5,5	4,5	4,7	4,7	4,8	5,0	5,0	
direct	direct	direct	direct	QC	QC	QC	QC	QC	QC	
C76	C77	C12	C13	Q251 + QC86	Q251 + QC87	Q251 + QC88	Q251 + QC82	Q251 + QC83	Q251 + QC84	
1,75	1,65	1,70	1,6	1,7	1,6	1,6	1,6	1,5	1,5	
2.480	2.535	2.555	2.615	2200	2255	2355	2275	2330	2430	
20.900	20.680	20.770	20.575	18.920	18.745	18.610	18.765	18.600	18.460	+ 720
18.000	17.800	17.880	17.700	16.225	16.065	15.935	16.080	15.925	15.790	+ 635
204	194	197	188	179	171	171	172	165	165	
219	216	217	215	198	197	196	191	195	194	
26.855	26.910	26.930	26.985	27.300	27.355	27.455	27.375	27.435	27.535	+ 1.040
6.970	6.970	6.970	6.970	6.970	6.970	6.970	6.970	6.970	6.970	
7.840	7.785	7.860	7.800	7.920	7.860	7.920	7.950	7.890	7.950	
1.695	1.540	1.730	1.575	1.805	1.650	1.805	1.860	1.705	1.860	- 35
2.850	2.980	2.815	2.945	2.660	2.790	2.660	2.605	2.735	2.605	+ 45
4.485	4.485	4.485	4.485	4.485	4.485	4.485	4.485	4.485	4.485	
6.315	6.315	6.380	6.380	6.265	6.265	6.265	6.330	6.330	6.330	
140	170	140	170	195	225	225	195	225	225	
4.145	4.145	4.145	4.145	4.110	4.110	4.110	4.110	4.110	4.110	
9.690	9.510	9.740	9.560	9.945	9.765	9.970	10.025	9.840	10.045	
3.450	3.450	3.450	3.450	3.450	3.450	3.450	3.450	3.450	3.450	
3.170	3.170	3.170	3.170	3.170	3.170	3.170	3.170	3.170	3.170	
3.010	3.010	3.010	3.010	3.010	3.010	3.010	3.010	3.010	3.010	+ 35
2.300	2.300	2.300	2.300	2.300	2.300	2.300	2.300	2.300	2.300	
505	505	505	505	505	505	505	505	505	505	
3.575	3.575	3.575	3.575	3.575	3.575	3.575	3.575	3.575	3.575	+ 45

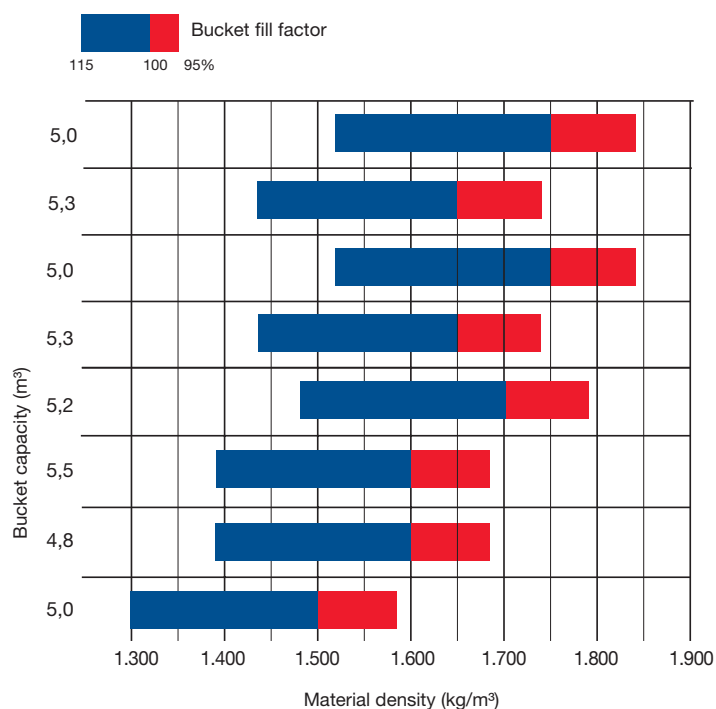

Standard and Optional Equipment

ENGINE

Komatsu SAA6D125E-7 turbocharged common rail direct injection diesel engine	●
EU Stage V compliant	●
Engine mode selection system: Power, Economy, E-Light	●
Komatsu SmartLoader Logic	●
Adjustable idle shutdown	●
Auto-deceleration function	●
Fuel filter with water separator	●
Batteries 2 × 180 Ah/2 × 12 V	●

CHASSIS AND TYRES

Heavy-duty axles	●
Front fenders	●
Full rear fenders	●
Limited-slip differential (LSD) front and rear	○
Tyres 26.5 R25 L2, L3, L5	○

HYDRAULIC SYSTEM

2-spool main control valve	●
EPC fingertip control, two levers, including:	●
- Bucket stop modulation	●
- Boom stop pre-setting	●
- Automatic dig function	●
Automatic return-to-dig	●
3-spool main control valve	○
EPC fingertip control, three levers	○
EPC 1-lever (Multi-function lever) with sliding proportional control for attachments	○
Biodegradable oil for hydraulic system	○

TRANSMISSION AND BRAKES

Electronically controlled ECMV automatic transmission with mode selector and variable transmission cut-off	●
Transmission shift mode selection system	●
Large-capacity torque converter	●
Torque converter lock-up	●
Auto-kickdown	●
Axle oil cooling system	●

CABIN

Spacious double door driver's cab to DIN/ISO	●
ROPS/FOPS frame according to SAE	●
Heated, high back air suspension seat, console mounted height adjustable arm rests	●
Retractable seat belt	●
Automatic climate control system	●
Multi-function video compatible colour monitor with Equipment Management and Monitoring System (EMMS) and efficiency guidance	●
DAB+ digital radio w. auxiliary input (MP3 jack)	●
Hot and cool box	●
Heated rear window	●
Rear window wiper	●
Adjustable steering column	●
2× 12 V power supply	●
Heated, high back air suspension seats with pneumatically adjustable lumbar support, console mounted height adjustable arm rests	○
3-point seat belt	○
Sun roller blind	○
Komatsu short lever steering (K-SLS)	○

LIGHTING SYSTEM

2 halogen main headlights	●
2 spotlights at front and rear	●
Reversing light	●
Additional lights front and rear	○
LED working lights	○
Xenon working lights	○

SERVICE AND MAINTENANCE

Hydrostat-driven radiator fan with automatic reversing function	●
Wide-core radiator	●
KOMTRAX – Komatsu wireless monitoring system (3G)	●
Komatsu CARE™ – a maintenance program for Komatsu customers	●
Tool-set	●
Automatic central lubrication	●
Filling tool for central lubrication system	○
Turbo II air pre-cleaner, cyclone type	○

SAFETY EQUIPMENT

Emergency steering system	●
Vandalism protection	●
Back-up alarm	●
Battery main switch	●
Handrails on left/right	●
Rear-view camera system	●
Front screen protective grid	○
Fire extinguisher	○
Beacon light	○
Roof rail	○
Rear view mirror, heated and remote control	○
Optical back-up alarm (strobe light)	○

ATTACHMENTS

High efficiency buckets with flat or raised bottom	○
High-dump buckets	○
Waste handling buckets	○
Light material buckets	○
Hydraulic quick-coupler	○
Fork carrier and tines	○

OTHER EQUIPMENT

Counterweight	●
Electronically controlled load stabilizer (ECSS II)	●
Add. counterweight 400 kg (A15)	●
Special custom colour	○
Weighing system RDS Loadmaster alpha100	○
Cold area kit (engine and cab pre-heating)	○
Aggregate handling specification	○

Further equipment on request

- standard equipment
- optional equipment

Your Komatsu partner:

KOMATSU

**Komatsu Europe
International N.V.**

Mechelsesteenweg 586
B-1800 VILVOORDE (BELGIUM)
Tel. +32-2-255 24 11
Fax +32-2-252 19 81
www.komatsu.eu

VENSS06705 03/2022

KOMATSU is a trademark of Komatsu Ltd. Japan.