

KOMATSU

PC490HRD-11

EU Stage V Engine

HIGH REACH DEMOLITION

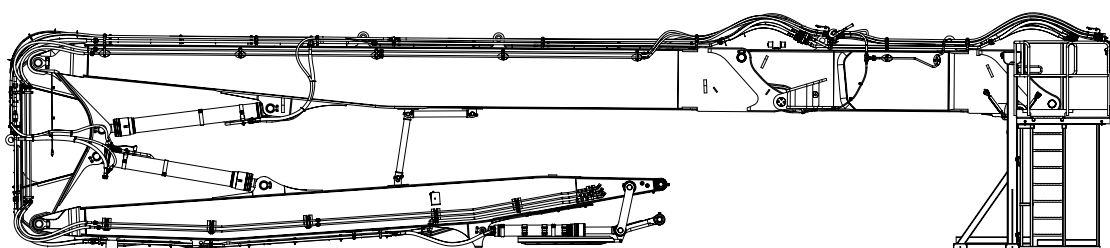
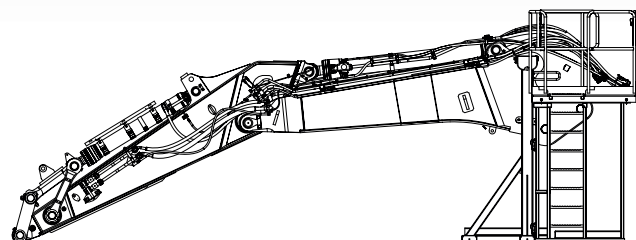
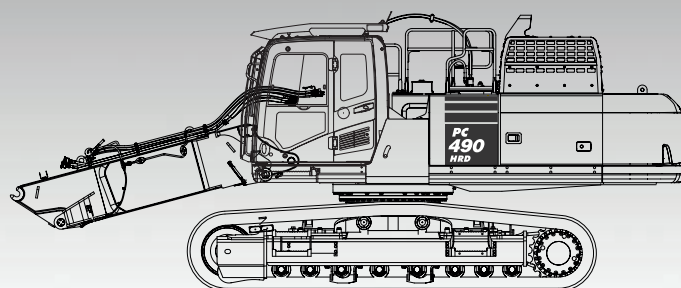

ENGINE POWER

270 kW / 362 HP @ 1.900 rpm

OPERATING WEIGHT

55.200 - 73.400 kg

MAX. ATTACHMENT WEIGHT

Medium Reach Demolition:

5.000 kg

High Reach Demolition:

3.350 kg

Extended High Reach Demolition:

2.000 kg

PC490

Specifications

ENGINE

Model	Komatsu SAA6D125E-7
Type	Common rail direct injection, water-cooled, emissionised, turbocharged, after-cooled diesel
Engine power	
at rated engine speed	1.900 rpm
ISO 14396	270 kW / 362 HP
ISO 9249 (net engine power)	268 kW / 359 HP
No. of cylinders	6
Bore x stroke	125 x 150 mm
Displacement	11,04 l
Air filter type	Double element type with monitor panel dust indicator and auto dust evacuator
Fan drive type	Hydraulic, reversible

HYDRAULIC SYSTEM

Type	HydrauMind. Closed-centre system with load sensing and pressure compensation valves
Additional circuits	2 additional circuits with proportional control are installed
Main pump	2 variable displacement piston pumps supplying boom, arm, bucket, swing and travel circuits
Maximum pump flow	2 x 345 l/min
Relief valve settings	
Implement	380 kg/cm ²
Travel	380 kg/cm ²
Swing	285 kg/cm ²
Pilot circuit	33 kg/cm ²

SERVICE REFILL CAPACITIES

Fuel tank	650 l
Radiator	47,0 l
Engine oil	37,0 l
Swing drive	20,0 l
Hydraulic tank	248 l
Final drive (each side)	10,5 l
AdBlue® tank	39,0 l

OPERATING WEIGHT (APPR.)

Triple grouser shoes	Extended High Reach Demolition		High Reach Demolition		Medium Reach Demolition		Excavation Boom	
	Operating weight	Ground pressure	Operating weight	Ground pressure	Operating weight	Ground pressure	Operating weight	Ground pressure
600 mm	–	–	65.400 kg	1,19 kg/cm ²	66.750 kg	1,22 kg/cm ²	55.200 kg	1,01 kg/cm ²
700 mm	–	–	65.900 kg	1,03 kg/cm ²	67.250 kg	1,05 kg/cm ²	55.700 kg	0,87 kg/cm ²
700 mm HWG	73.400 kg	1,07 kg/cm ²	71.250 kg	1,04 kg/cm ²	72.650 kg	1,06 kg/cm ²	61.050 kg	0,89 kg/cm ²
Attachment weight	2.000 kg		3.350 kg		5.000 kg		1.915 kg (bucket)	

Operating weight, including specified work equipment, operator, lubricant, coolant, full fuel tank and the standard equipment.

SWING SYSTEM

Type	Axial piston motor driving through planetary double reduction gearbox
Swing lock	Electrically actuated wet multidisc brake integrated into swing motor
Swing speed (restricted MR/HRD)	0 - 9,6 (3,3) rpm
Swing torque	132 kNm

DRIVES AND BRAKES

Steering control	2 levers with pedals giving full independent control of each track
Drive method	Hydrostatic
Travel operation	Automatic 3-speed selection
Gradeability	70%, 35°
Max. travel speeds	
Lo / Mi / Hi	3,0 / 4,2 / 5,5 km/h
Maximum drawbar pull	34.000 kg
Brake system	Hydraulically operated discs in each travel motor

UNDERCARRIAGE

Construction	X-frame centre section with box section track frames
Track assembly	
Type	Fully sealed
Shoes (each side)	49
Tension	Combined spring and hydraulic unit
Rollers	
Track rollers (each side)	LC: 8 / HWG: 9
Carrier rollers (each side)	LC: 2 / HWG: 3

ENVIRONMENT

Engine emissions	Fully complies with EU Stage V exhaust emission regulations
Noise levels	
LwA external	107 dB(A) (2000/14/EC Stage II)
LpA operator ear	71 dB(A) (ISO 6396 dynamic test)
Vibration levels (EN 12096:1997)	
Hand/arm	≤ 2,5 m/s ² (uncertainty K = 0,25 m/s ²)
Body	≤ 0,5 m/s ² (uncertainty K = 0,25 m/s ²)
Contains fluorinated greenhouse gas HFC-134a (GWP 1430). Quantity of gas 0,8 kg, CO ₂ equivalent 1,14 t	

PG490HRD-11

Basic Dimensions

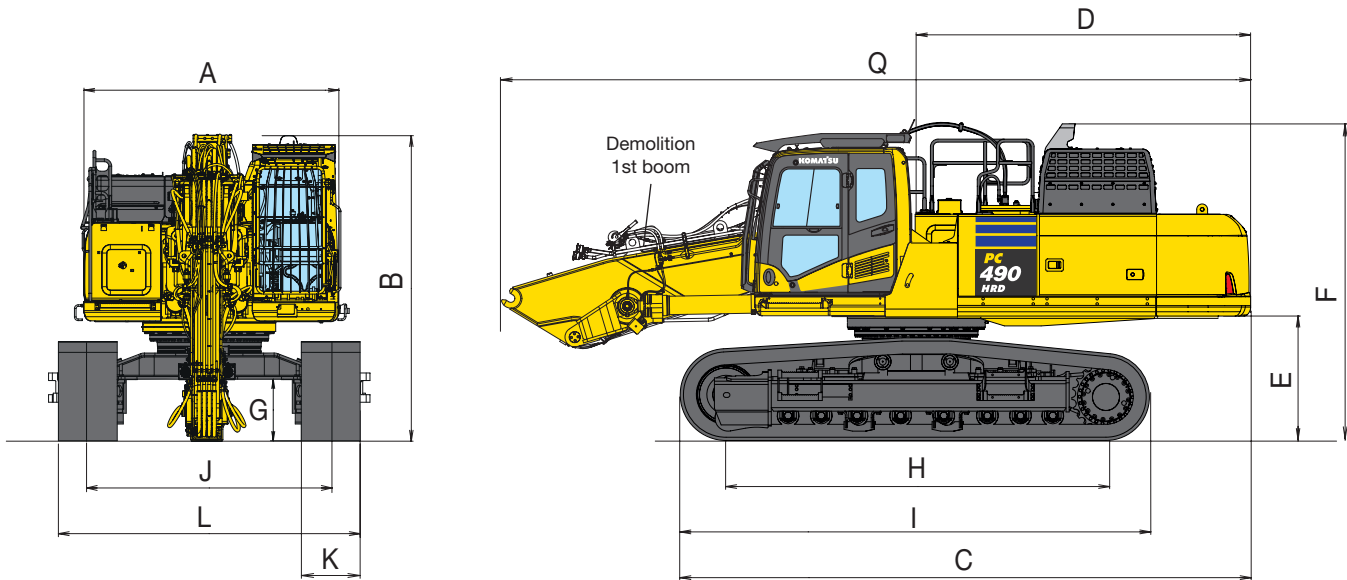

TRANSPORT DIMENSIONS

Undercarriage	LC	HWG
A Overall width of upper structure ¹⁾	2.995 mm	2.995 mm
B Overall height of cab, with FOPS	3.570 mm	3.600 mm
Overall height of cab, without FOPS	3.360 mm	3.390 mm
C Overall length of basic machine	6.525 mm	6.690 mm
D Tail length	3.830 mm	3.830 mm
E Clearance under counterweight	1.385 mm	1.415 mm
F Machine tail height	3.630 mm	3.660 mm
G Ground clearance	700 mm	500 mm
H Tumbler centre distance	4.350 mm	4.680 mm
I Track length	5.385 mm	5.695 mm
J Track gauge ²⁾	2.390 - 2.890 mm	2.280 - 3.280 mm
K Track shoe width	600 mm, 700 mm	700 mm
L Overall track width with 600 mm shoes ²⁾	2.990 - 3.490 mm	-
Overall track width with 700 mm shoes ²⁾	3.090 - 3.590 mm	2.980 - 3.980 mm
Q Transport length	8.445 mm	8.445 mm
Transport weight (600 mm shoe) ³⁾	47.050 kg	-
Transport weight (700 mm shoe) ³⁾	47.550 kg	52.900 kg

¹⁾ Overall width of upper structure excludes side guards, handrails and mirrors. Side guards can be removed if transport width of less than 3 m is required.

²⁾ Undercarriage in retracted – extended position

³⁾ Transport weights exclude additional counterweight.

Transport Dimensions

EXTENDED HIGH REACH DEMOLITION

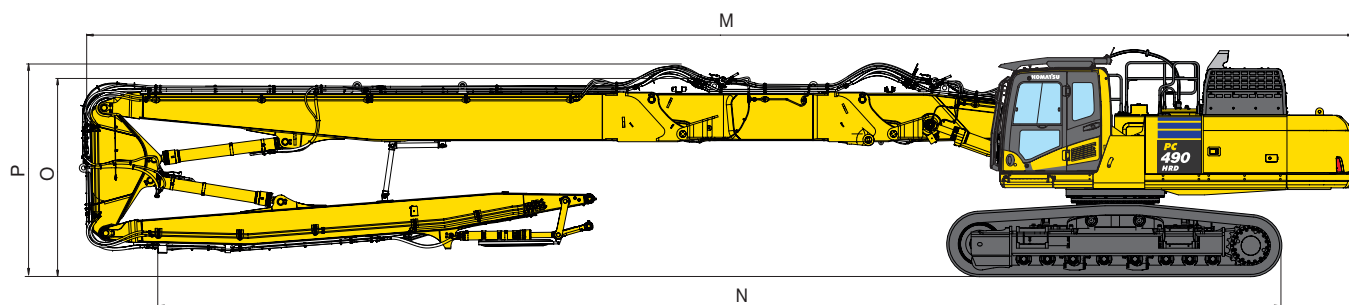

M	Overall transport length	23.215 mm
N	Transport length on ground	21.720 mm
O	Transport height (to top of boom)	3.320 mm
P	Transport height (to top of hose)	3.600 mm
	Transport weight (HWG undercarriage, 700 mm shoe, including additional counterweight)	71.325 kg

HIGH REACH DEMOLITION

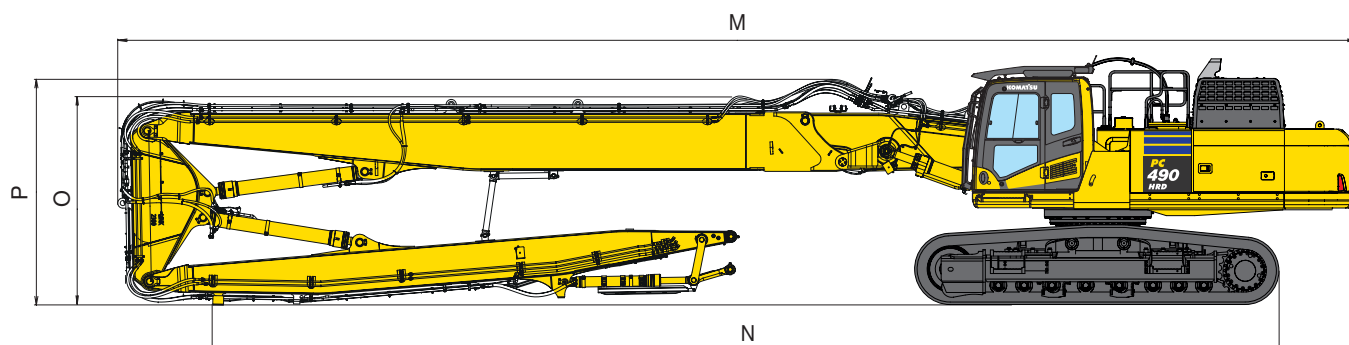

M	Overall transport length	19.215 mm
N	Transport length on ground	16.540 mm
O	Transport height (to top of boom)	3.320 mm
P	Transport height (to top of hose)	3.550 mm
	Transport weight (LC undercarriage, 700 mm shoe, including additional counterweight)	62.475 kg

MEDIUM REACH DEMOLITION – STRAIGHT POSITION

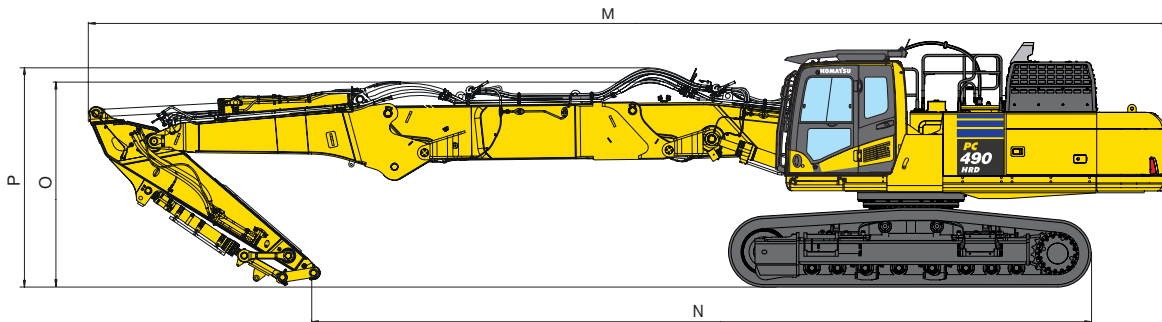

M	Overall transport length	17.250 mm
N	Transport length on ground	12.980 mm
O	Transport height (to top of boom)	3.420 mm
P	Transport height (to top of hose)	3.590 mm
	Transport weight (LC undercarriage, 700 mm shoe, including additional counterweight)	62.175 kg

MEDIUM REACH DEMOLITION – CRANKED POSITION

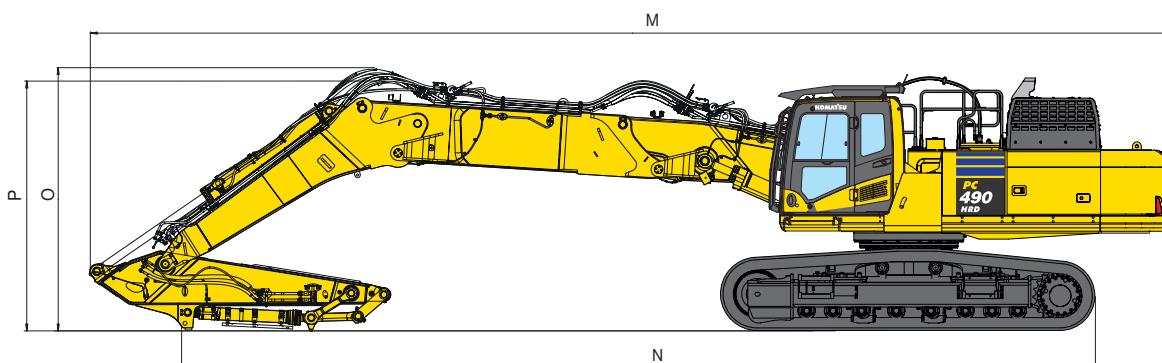

M	Overall transport length	16.480 mm
N	Transport length on ground	11.935 mm
O	Transport height (to top of boom)	3.700 mm
P	Transport height (to top of hose)	3.975 mm
	Transport weight (LC undercarriage, 700 mm shoe, including additional counterweight)	62.175 kg

Transport Dimensions

EXCAVATION BOOM – STRAIGHT POSITION

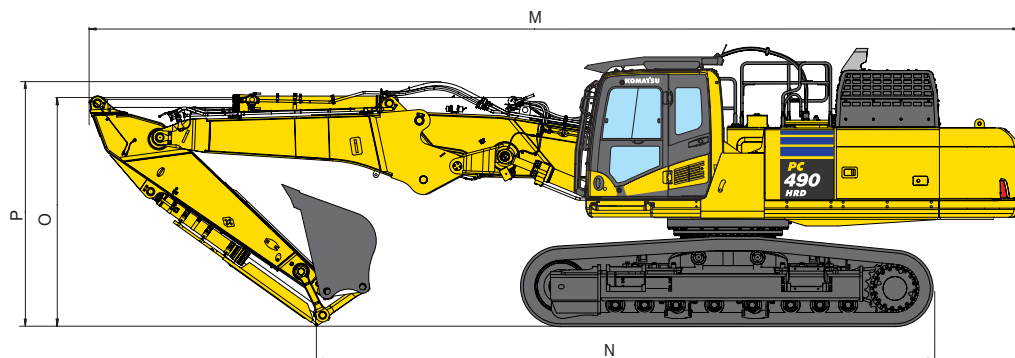

M	Overall transport length	13.210 mm
N	Transport length on ground	8.690 mm
O	Transport height (to top of boom)	3.215 mm
P	Transport height (to top of hose)	3.560 mm
	Transport weight (LC undercarriage, 700 mm shoe, including 1.915 kg bucket)	55.625 kg

EXCAVATION BOOM – CRANKED POSITION

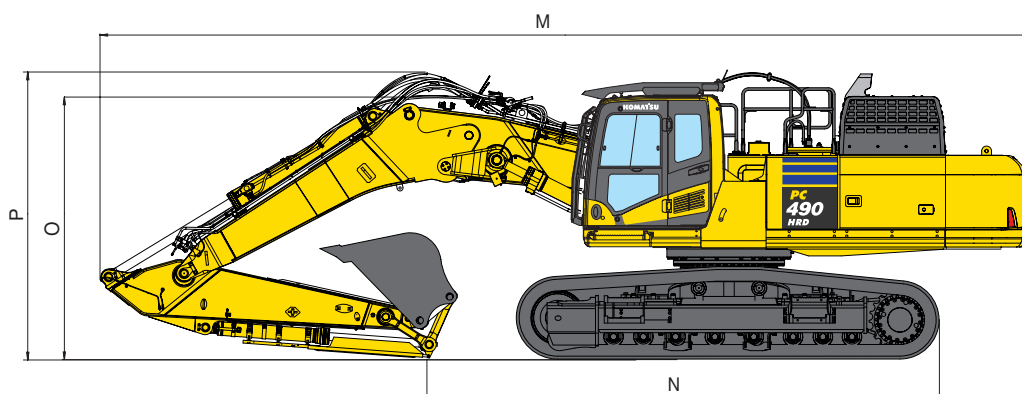

M	Overall transport length	12.565 mm
N	Transport length on ground	6.820 mm
O	Transport height (to top of boom)	3.700 mm
P	Transport height (to top of hose)	3.980 mm
	Transport weight (LC undercarriage, 700 mm shoe, including 1.915 kg bucket)	55.625 kg

Work Equipment Storage Dimensions

EXTENDED HIGH REACH DEMOLITION

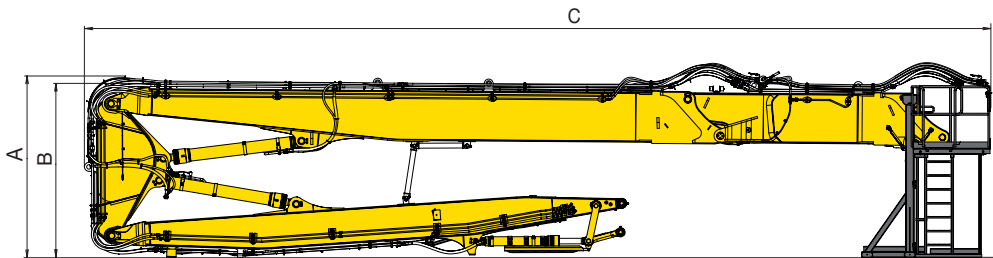

HIGH REACH DEMOLITION

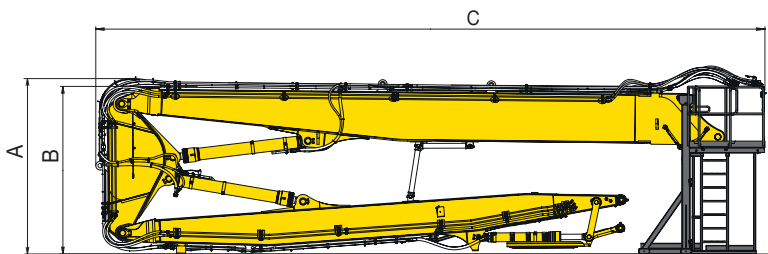

MEDIUM REACH DEMOLITION

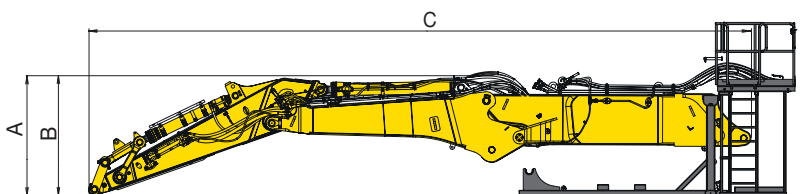

EXCAVATION BOOM

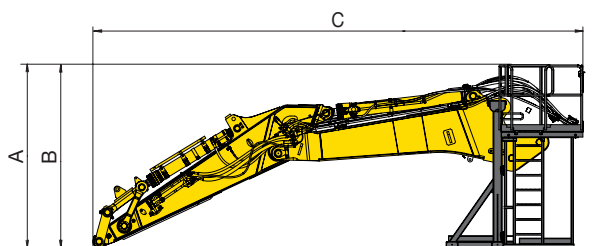

EXTENSION

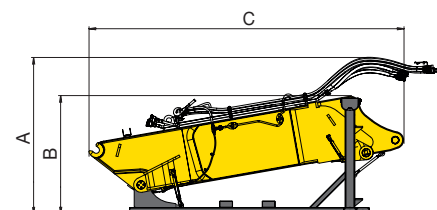

	Extended High Reach Demolition	High Reach Demolition	Medium Reach Demolition	Excavation Boom	Extension
A	3.465 mm	3.465 mm	3.100 mm	3.100 mm	–
B	3.210 mm	3.210 mm	3.100 mm	3.100 mm	1.820 mm
C	16.310 mm	12.315 mm	12.670 mm	8.360 mm	4.875 mm
Transport weight*	14.500 kg	11.000 kg	10.700 kg	7.200 kg	4.000 kg

* Transport weight includes equipment stands and excludes attachment/bucket.

Working Range

EXTENDED HIGH REACH DEMOLITION

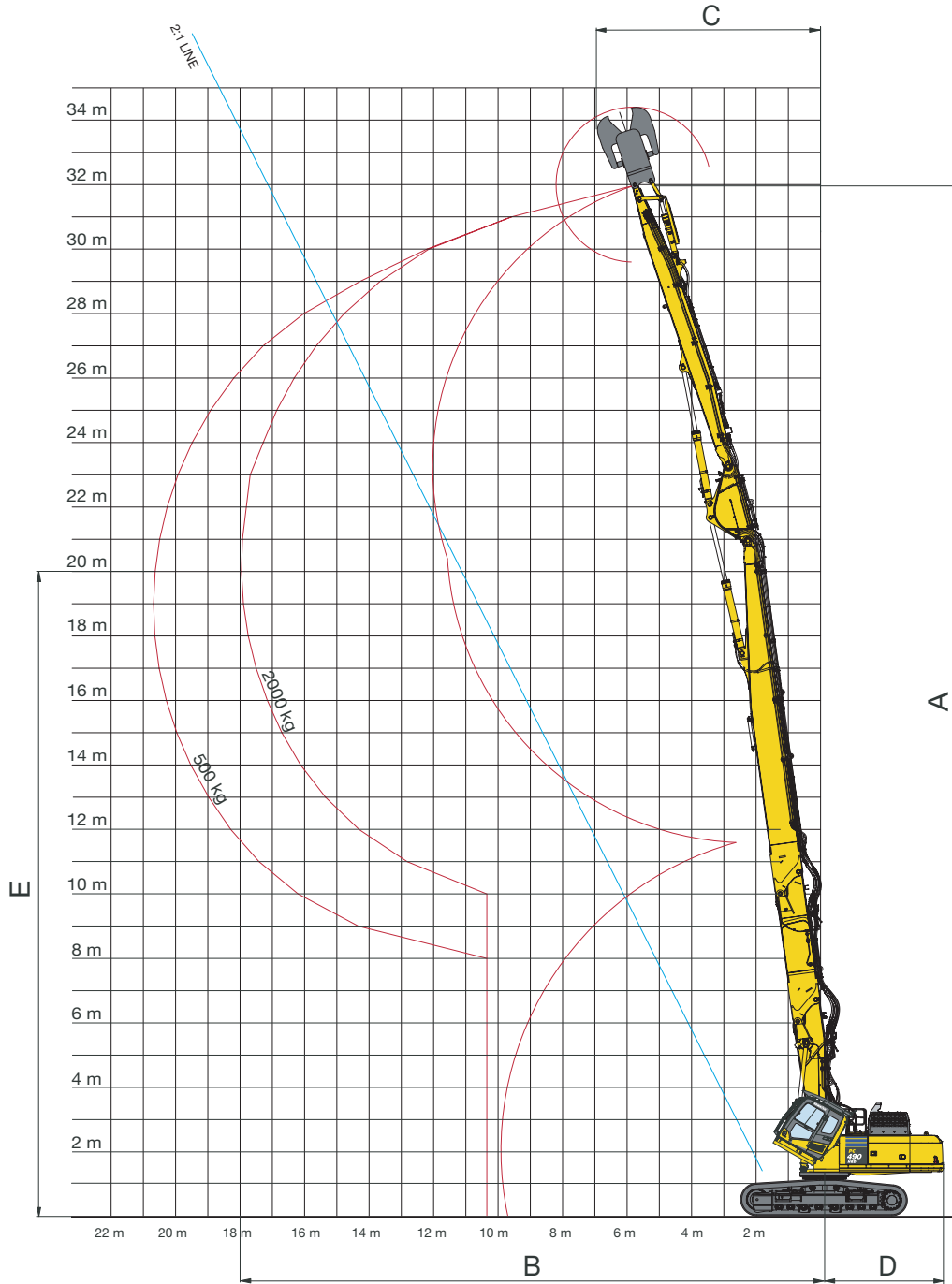

EXTENDED HIGH REACH DEMOLITION

OVER FRONT

OVER SIDE

A	Max. height (to pin at arm end)	32.000 mm	32.000 mm
B	Max. forward reach (max. tool weight)	18.000 mm	16.450 mm
C	Min. swing radius of arm end pin at max. height	5.800 mm	5.800 mm
D	Tail swing radius	3.860 mm	3.860 mm
E	Height at max. reach	20.000 mm	20.000 mm
	Max. height (2:1 line)	27.800 mm	26.900 mm
	Reach at max. height (2:1 line)	15.000 mm	14.650 mm

HIGH REACH DEMOLITION

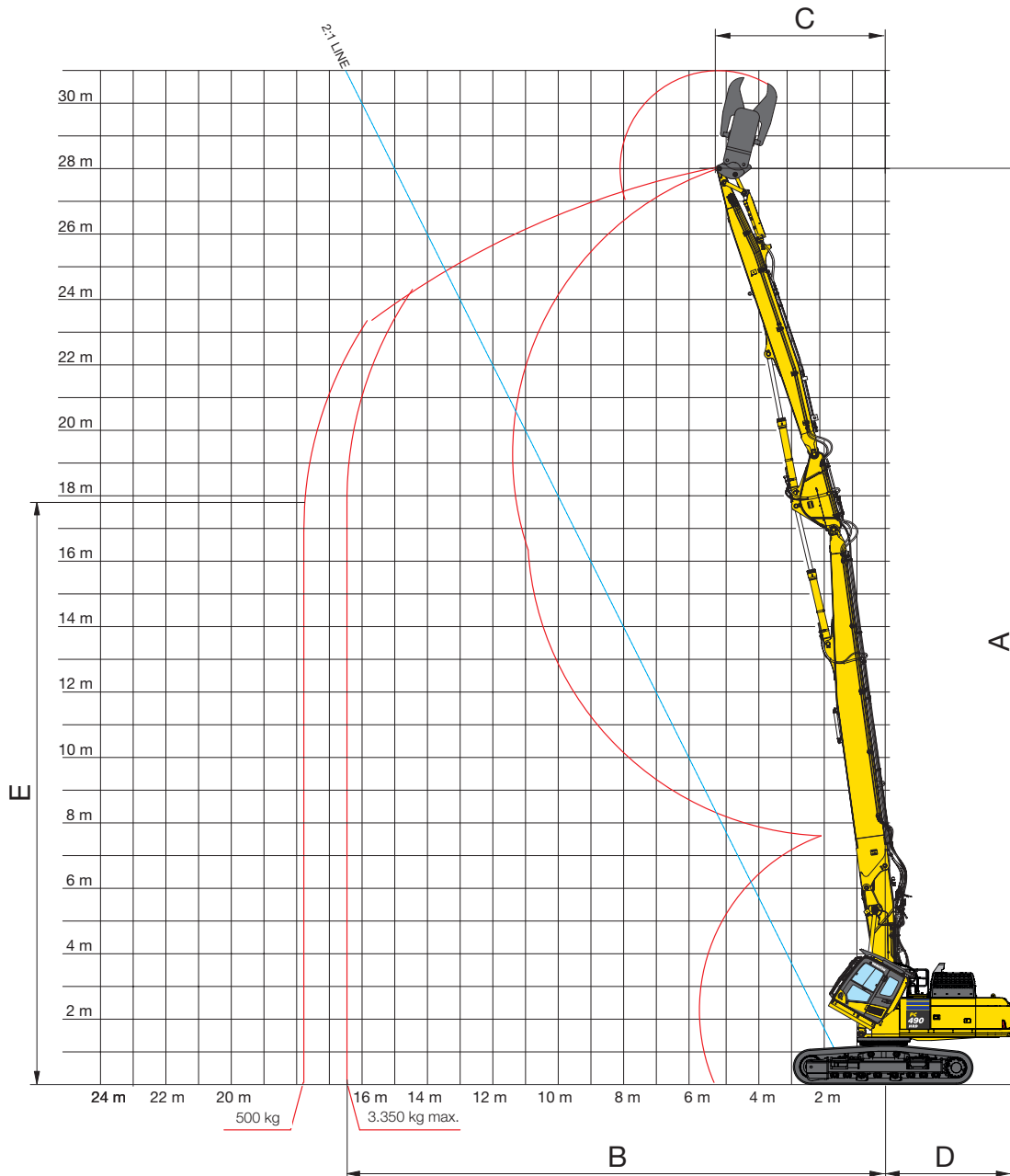

HIGH REACH DEMOLITION	OVER FRONT	OVER SIDE
A Max. height (to pin at arm end)	28.000 mm	28.000 mm
B Max. forward reach (max. tool weight)	16.500 mm	14.350 mm
C Min. swing radius of arm end pin at max. height	5.250 mm	5.250 mm
D Tail swing radius	3.860 mm	3.860 mm
E Height at max. reach	17.795 mm	16.950 mm
Max. height (2:1 line)	24.925 mm	24.850 mm
Reach at max. height (2:1 line)	13.465 mm	13.550 mm

Working Range

MEDIUM REACH DEMOLITION – STRAIGHT POSITION

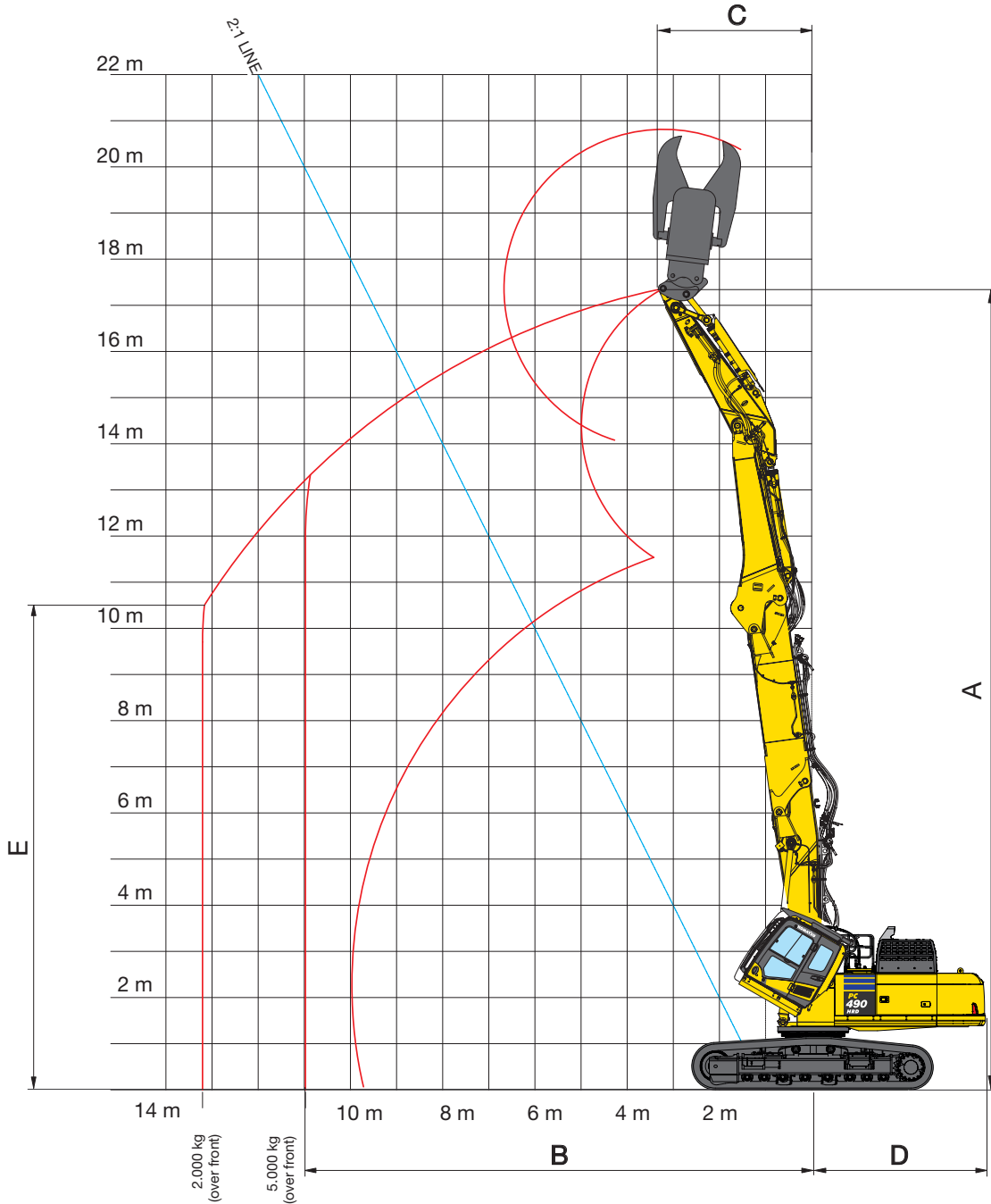

MEDIUM REACH DEMOLITION – STRAIGHT POSITION

	OVER FRONT	OVER SIDE
A Max. height (to pin at arm end)	17.365 mm	17.365 mm
B Max. forward reach (max. tool weight)	11.000 mm	9.400 mm
C Min. swing radius of arm end pin at max. height	3.220 mm	3.220 mm
D Tail swing radius	3.860 mm	3.860 mm
E Height at max. reach	11.940 mm	13.000 mm
Max. height (2:1 line)	15.160 mm	15.160 mm
Reach at max. height (2:1 line)	8.580 mm	8.580 mm

MEDIUM REACH DEMOLITION – CRANKED POSITION

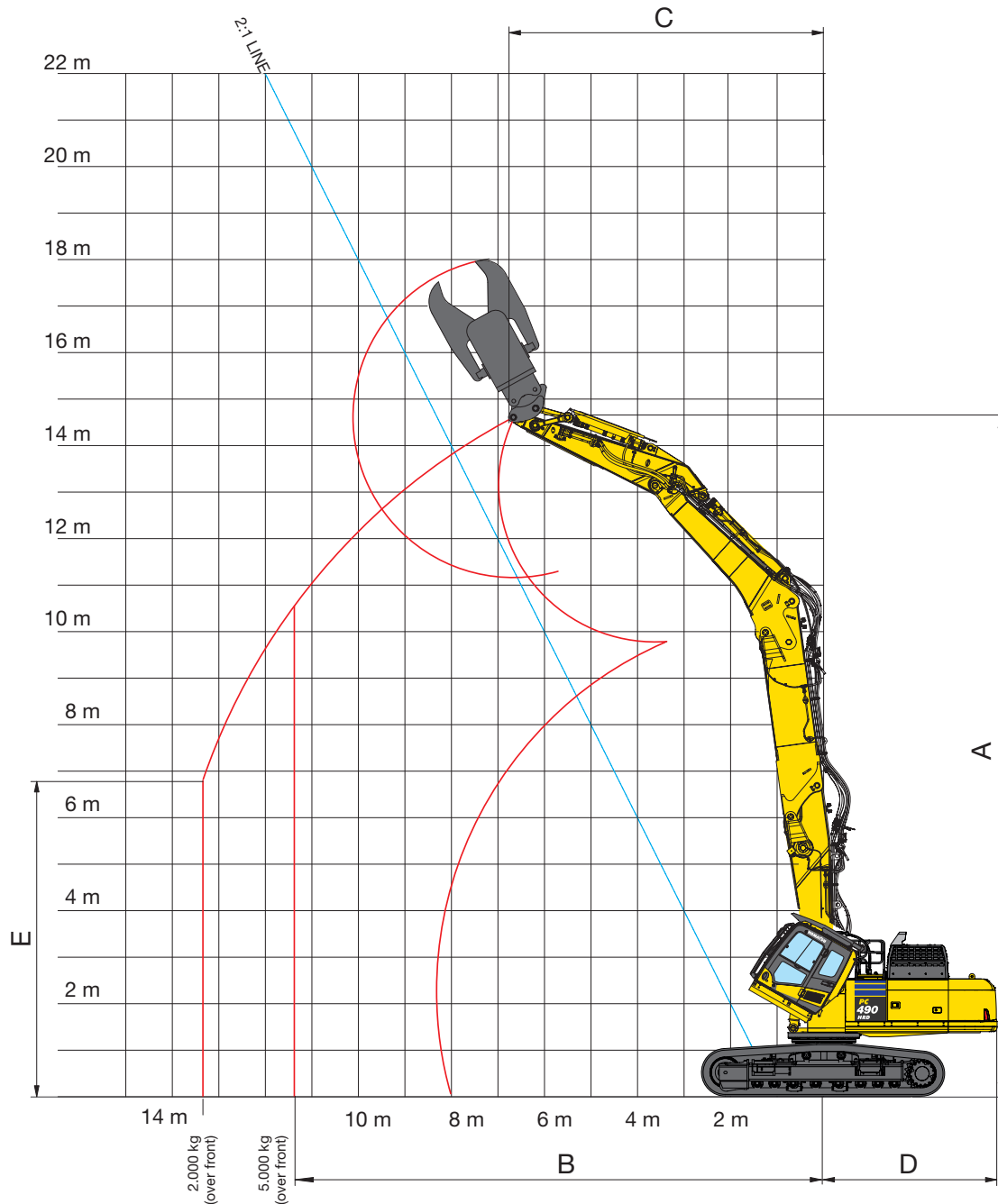

MEDIUM REACH DEMOLITION – CRANKED POSITION	OVER FRONT	OVER SIDE
A Max. height (to pin at arm end)	14.610 mm	14.610 mm
B Max. forward reach (max. tool weight)	11.400 mm	9.900 mm
C Min. swing radius of arm end pin at max. height	6.670 mm	6.670 mm
D Tail swing radius	3.860 mm	3.860 mm
E Height at max. reach	10.550 mm	12.260 mm
Max. height (2:1 line)	13.855 mm	13.855 mm
Reach at max. height (2:1 line)	7.930 mm	7.930 mm

Working Range

EXCAVATION BOOM – CRANKED POSITION

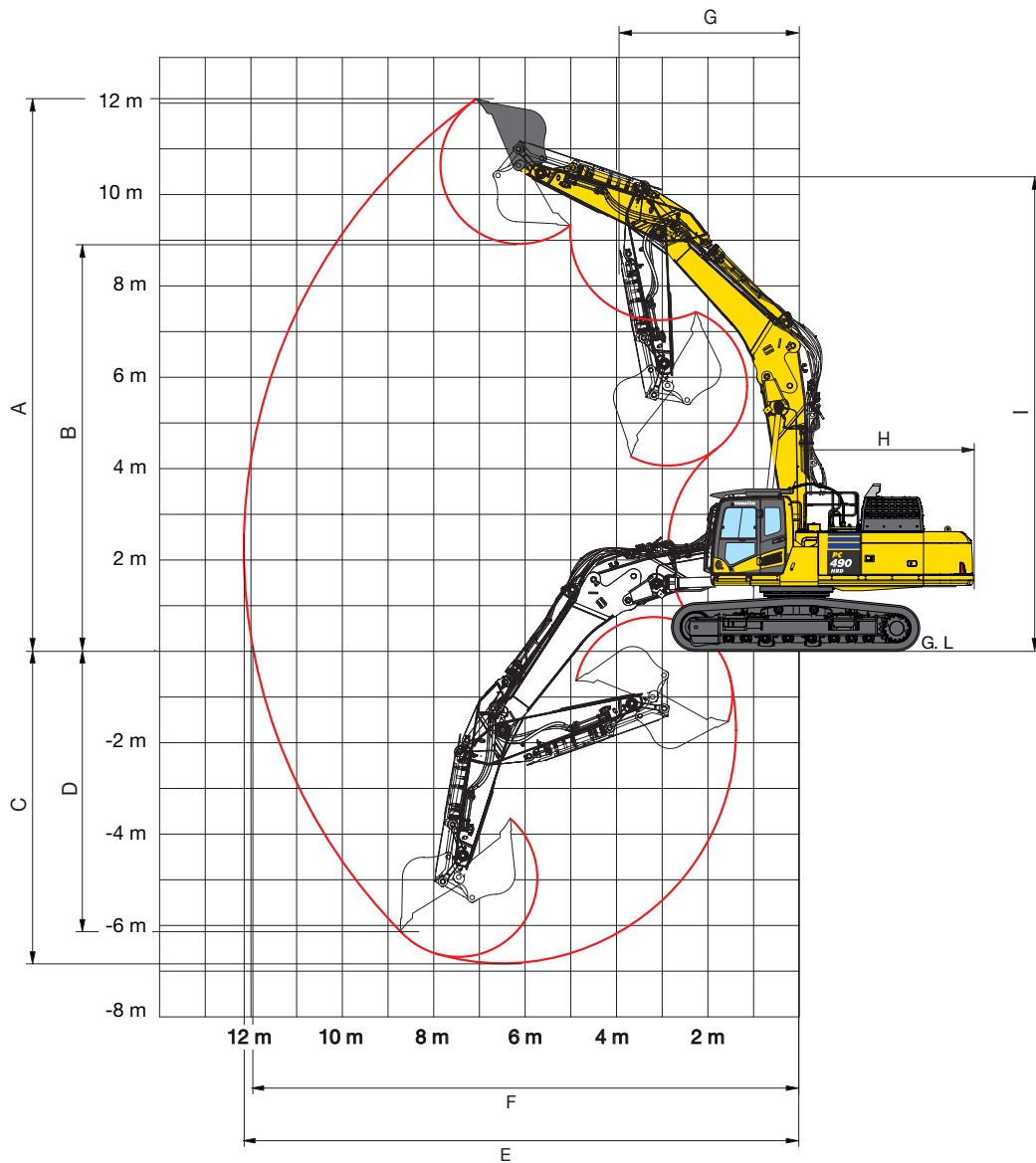

ARM LENGTH

3,4 m

A	Max. digging height	12.090 mm
B	Max. dumping height	8.980 mm
C	Max. digging depth	6.830 mm
D	Max. vertical wall digging depth	6.175 mm
E	Max. digging reach	12.155 mm
F	Max. digging reach at ground level	11.940 mm
G	Min. swing radius (bucket loaded)	3.860 mm
H	Tail swing radius	3.860 mm
I	Max. height at min. swing radius	10.195 mm

EXCAVATION BOOM – STRAIGHT POSITION

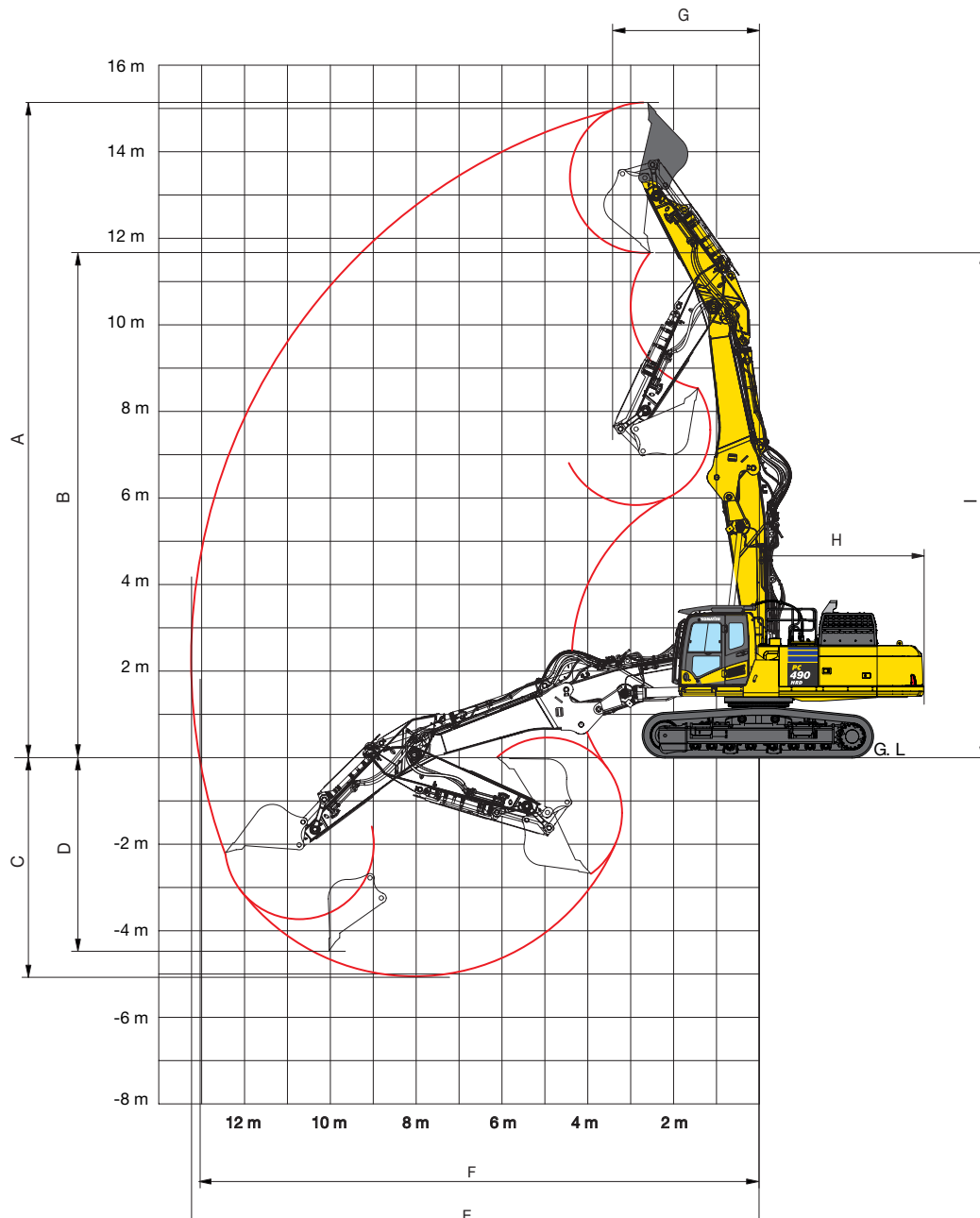

ARM LENGTH	3,4 m
A Max. digging height	15.075 mm
B Max. dumping height	11.600 mm
C Max. digging depth	5.120 mm
D Max. vertical wall digging depth	4.510 mm
E Max. digging reach	13.250 mm
F Max. digging reach at ground level	13.060 mm
G Min. swing radius (bucket loaded)	3.415 mm
H Tail swing radius	3.860 mm
I Max. height at min. swing radius	11.480 mm

Lifting Capacity

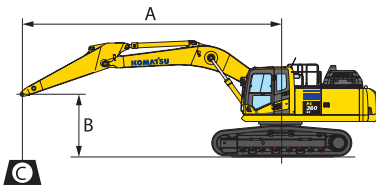

A – Reach from swing center

B – Bucket hook height

C – Lifting capacities

– Rating over front

– Rating over side

– Rating at maximum reach

Weights:

Bucket linkage, bucket cylinder, including cylinder guard: 570 kg

With 600 mm shoes

EXCAVATION BOOM – CRANKED POSITION

Arm length	A				10,5 m		9,0 m		7,5 m		6,0 m		4,5 m	
	B													
 3,4 m	9,0 m	kg	*6.000	*6.000					*8.650	*8.650				
	7,5 m	kg	*5.900	*5.900			*7.100	*7.100	*12.300	*12.300				
	6,0 m	kg	*6.050	*6.050			*11.650	8.600	*14.150	12.050	*16.800	*16.800		
	4,5 m	kg	*6.400	6.300			12.650	8.250	*15.550	11.350	*19.150	16.450	*26.500	25.950
	3,0 m	kg	*7.000	5.800	*9.250	5.850	12.200	7.850	16.550	10.650	*21.700	15.150	*20.600	*20.600
	1,5 m	kg	*7.850	5.600	9.050	5.650	11.750	7.450	15.850	10.000	22.850	14.050		
	0,0 m	kg	9.150	5.650	8.850	5.450	11.400	7.100	15.300	9.500	22.000	13.350	*13.550	*13.550
	-1,5 m	kg	9.700	5.950			11.200	6.900	15.000	9.250	21.650	13.000	*19.750	*19.750
	-3,0 m	kg	10.950	6.750			11.150	6.900	14.900	9.150	*20.700	13.050	*25.800	21.050
	-4,5 m	kg	*11.850	8.350					*13.700	9.300	*17.450	13.250	*21.300	21.250

EXCAVATION BOOM – STRAIGHT POSITION

Arm length	A				10,5 m		9,0 m		7,5 m		6,0 m		4,5 m	
	B													
 3,4 m	9,0 m	kg	*6.250	*6.250			*10.000	8.300	*12.250	11.950	*11.900	*11.900		
	7,5 m	kg	*5.950	5.850	*6.100	5.900	*12.500	8.250	*13.150	11.650	*12.550	*12.550	*13.450	*13.450
	6,0 m	kg	*5.900	5.100	9.300	5.850	12.400	8.000	*17.000	11.150	*20.100	16.250	*25.900	*25.900
	4,5 m	kg	*6.000	4.600	9.100	5.700	11.950	7.650	16.300	10.450	*22.700	14.950		
	3,0 m	kg	*6.250	4.350	8.900	5.500	11.550	7.250	15.550	9.750	22.450	13.750		
	1,5 m	kg	*6.600	4.300	8.700	5.300	11.150	6.900	15.000	9.250				
	0,0 m	kg	*7.250	4.400	8.550	5.150	10.950	6.700	14.600	8.900	*17.750	12.550		
	-1,5 m	kg	*7.200	4.700	8.500	5.150	10.850	6.600	*14.500	8.800	*17.550	12.600		
	-3,0 m	kg					*9.500	6.650	*12.000	8.900	*13.650	12.700		

* Load is limited by hydraulic capacity rather than tipping.

Ratings are based on SAE Standard No. J1097.

Rated loads do not exceed 87% of hydraulic lift capacity or 75% of tipping load.

Lifting capacities are stated in kg, on the tip of the arm, for machine on firm, level supporting surface.

Standard and Optional Equipment

ENGINE

Komatsu SAA6D125E-7 turbocharged common rail direct injection diesel engine	●
EU Stage V compliant	●
Remote hydraulically driven, variable speed, reversible cooling fan	●
Automatic engine warm-up system	●
Engine overheat prevention system	●
Fuel control dial	●
Auto-deceleration function	●
Adjustable idle shutdown	●
Engine key stop	●
Engine ignition can be password secured on request	●
Alternator 24 V / 90 A	●
Starter motor 24 V / 11 kW	●
Batteries 2 × 12 V / 180 Ah	●

HYDRAULIC SYSTEM

Electronic closed-centre load sensing (E-CLSS) hydraulic system (HydraMind)	●
Pump and engine mutual control (PEMC) system	●
6-working mode selection system; power mode, economy mode, breaker mode, attachment power and attachment economy mode, and lifting mode	●
PowerMax function	●
Two-mode boom control	●
In-line filter for hydraulics	●
Two additional service valves (full flow)	●
One additional service valve (1/2 flow)	●
Drain circuit for hydraulic attachment rotation motors	●
Prepared for hydraulic quick coupler	●
Adjustable PPC wrist control levers for arm, boom, bucket and swing, with sliding proportional control for attachments and 3 auxiliary buttons	●
PPC pedal for high reach demolition mid link	●
Tool Control system	○

DRIVES AND BRAKES

Hydrostatic, 3-speed travel system with automatic shift and planetary gear type final drives, and hydraulic travel and parking brakes	●
PPC control levers and pedals for steering and travel	●

LIGHTING SYSTEM

Working lights: 2 revolving frame lights and 2 LED boom lights, 4 LED cab roof (front) lights, 1 cab roof rear light, 1 counterweight (rear) light, 2 LED high reach arm lights	●
---	---

CABIN

Demolition specification Safety SpaceCab™, with ISO10262 level 2 FOPS guards and roof screen wash wipe system. Fixed, one piece front window. Front and roof window fitted with high impact protective laminated glass, compliant with EN356 Grade P5A, in accordance with EN474 Part 1: Annex G.	●
Tilting cab, controlled by wrist controller buttons, with soft start/soft stop function, including hydraulic power hoses and cab raise cylinders	●
Heated, high back air suspension seat with lumbar support, console mounted height adjustable arm rests, and retractable seat belt	●
Automatic climate control system	●
12 / 24 Volt power supplies	●
Beverage holder and magazine rack	●
Hot and cool box	●
Radio	●
Auxiliary input (MP3 jack)	●
Parallel action wiper with flick wipe function operated by wrist controller button	●

WORK EQUIPMENT

Demolition 1st boom: Includes demolition 1st boom, fitted with Komatsu hydraulic quick connect system and hydraulic pipework suitable for operation of rotating crusher attachment	●
High Reach Demolition: Includes heavy duty demolition 2nd boom, heavy duty mid link and heavy duty demolition arm, to fit onto demolition 1st boom. Includes work equipment stands compliant with EN474 Part 1: Annex G	○
Heavy Duty Extension boom: Includes extension boom to fit onto demolition 1st boom, with Komatsu hydraulic quick connect system, piping for hydraulic quick coupler and piping for hose burst valves. Includes equipment stand.	○
Excavation boom: Includes two position excavation boom to fit onto demolition 1st boom, 3.400 mm arm, with piping for hydraulic quick-coupler, arm cylinder safety valve. Includes work equipment stands compliant with EN474 Part 1: Annex G	○
Komatsu buckets	○

UNDERCARRIAGE

Track roller guards	●
Track frame under-guards	●
Hydraulic adjustable wide gauge (HWG) undercarriage	○
600, 700 mm triple grouser track shoes (HWG: 700 mm only)	○
Full length track roller guards	○

SAFETY EQUIPMENT

Working range indicator (WRI) system with full colour graphical display and warning buzzer. Compatible with optional high reach arm camera. 15 attachment memory settings	●
Komvison surround view system	●
Emergency engine stop switch	●
Electric horn	●
Lockable fuel cap and covers	●
Audible travel alarm	●
Boom, arm and mid link safety valves, compliant with EN474 Part 1: Annex G	●
Large handrails, rear-view mirrors	●
Battery main switch	●
Emergency cab lower switch (internal and external)	●
High reach arm end camera	○

SERVICE AND MAINTENANCE

Automatic fuel line de-aeration	●
Double element type air cleaner with dust indicator and auto dust evacuator	●
KOMTRAX™ – Komatsu wireless monitoring system	●
Komatsu CARE™ – a maintenance program for Komatsu customers	●
Multi-function video compatible colour monitor with Equipment Management and Monitoring System (EMMS) and efficiency guidance	●
Toolkit	●
Service points	●

OTHER EQUIPMENT

Heavy duty revolving frame with heavy duty demolition under covers and side guard protection	●
Counterweight prepared for demolition counterweight	●
Remote greasing for swing circle and pins	●
Electric refuelling pump with automatic shut off function	●
Standard colour scheme and decals	●
Parts book and operator manual	●
Additional counterweight. To fit into main demolition counterweight when high reach or medium reach demolition equipment is installed. Removable for excavation operations	○
Biodegradable oil for hydraulic system	○
Customised paint	○
Dust resistance kit, including turbine type engine air pre cleaner, mesh protection to air intakes	○

Further equipment on request

- standard equipment
- optional equipment

Your Komatsu partner:

KOMATSU

Komatsu Europe International N.V.
Mechelsesteenweg 586
B-1800 VILVOORDE (BELGIUM)
Tel. +32-2-255 24 11
Fax +32-2-252 19 81
www.komatsu.eu

UENSS19100 01/2019

KOMATSU is a trademark of Komatsu Ltd. Japan.

PG490HRD-11